



Installation & Operation Manual

VFH-MB/MC Series

Inverter Multi Zone Ductless Mini-Split

B-VFH09MB-1A

B-VFH12MB-1A

B-VFH18MC-1

B-VFH24MB-1

Attention

**ALL INVERTER MINI-SPLITS REQUIRE 14-4 STRANDED
WIRE BETWEEN THE INDOOR AND OUTDOOR UNITS
(NO EXCEPTIONS)**

14 AWG 4/C TRAY CABLE

A14/4SRBTHHNBK

**14 AWG (19/0147) BC 4/C, THHN CONDUCTORS POWER & CONTROL
TRAY CABLE TYPE TC CABLE FOR INSTALLATION IN
ACCORDANCE WITH ARTICLE 336 AND OTHER APPLICABLE PARTS
OF THE NATIONAL ELECTRIC CODE. 600V (UL) E123517 DIRECT
BURIAL SUNLIGHT RESISTANT PVC JACKET**

10/25/16

RoHS Compliant

MADE IN USA **BLACK**

ATTENTION

**When using a mini-split condensate pump
on a multi-head system,
the pump must be on a separate electrical circuit.
Do not access power from the indoor unit.**

Table of Contents

Part I : Technical Information	5
1. Summary	5
2. Specifications	6
2.1 Specification Sheet.....	6
2.2 Noise Curve.....	8
3. Outline Dimension Diagram	9
4. Refrigerant System Diagram	10
5. Electrical Part	11
5.1 Wiring Diagram.....	11
5.2 PCB Printed Diagram.....	12
6.Function and Control	13
6.1 Remote Controller Introduction	13
6.2 Brief Description of Modes and Functions.....	18
Part II : Installation and Maintenance	22
7.Notes for Installation and Maintenance	22
8. Installation	24
8.1 Installation Dimension Diagram.....	24
8.2 Installation Parts-checking	26
8.3 Selection of Installation Location.....	26
8.4 Electric Connection Requirement.....	26
8.5 Installation of Indoor Unit.....	26
8.6 Check after Installation and Test operation	29
9. Maintenance	30
9.1 Error Code.....	30
9.2 Procedure of Troubleshooting	32
10.Exploded View and Parts List	37
11.Removal Procedure	45
Appendix:	52
Appendix 1: Reference Sheet of Celsius and Fahrenheit	52
Appendix 2: Configuration of Connection Pipe.....	52
Appendix 3: Pipe expanding method.....	53
Appendix 4:List of Resistance for Temperature Sensor	54

Part I : Technical Information

1. Summary

Indoor Unit:

B-VFH09MB-1
B-VFH12MB-1
B-VFH18MC-1
B-VFH24MB-1

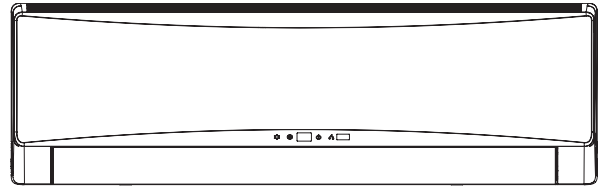

Remote Controller:

30510138_L61437

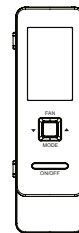

2. Specifications

2.1 Specification Sheet

Model		B-VFH09MB-1	B-VFH12MB-1
Product Code		CB148N07700_L61437	CB148N07800_L61437
Rated Voltage	V	208/230	208/230
Rated Frequency	Hz	60	60
Phases		1	1
Cooling Capacity	Btu/h	9000	12000
Heating Capacity	Btu/h	9800	13000
Air flow volume (SH/H/MH/M/ML/L/SL)	CFM	430/394/359/312/271/241/224	430/394/359/312/271/241/224
Dehumidifying Volume	L/h	0.8	1.4
Fan Type		Cross-flow	Cross-flow
Fan Diameter-height	inch	Φ3 55/64X26	Φ3 55/64X26
Fan Motor Speed (Cooling) (SH/H/MH/M/ML/L/SL)	rpm	1400/1050/1000/900/800/700/550	1450/1070/1000/900/800/700/550
Fan Motor Speed (Heating)(SH/H/MH/M/ML/L/SL)	rpm	1400/1150/1080/1030/980/900/850	1400/1150/1080/1030/980/900/850
Fan Motor Power Output	W	10	10
Fan motor running current	A	0.07	0.07
Fan Motor Capacitor	μF	/	/
Evaporator Material		Aluminum Fin-copper Tube	Aluminum Fin-copper Tube
Evaporator Pipe Diameter	inch	Φ9/32	Φ9/32
Evaporator Number of Rows-Fin Pitch	inch	2-1/16	2-1/16
Coil Length (LXDXW)	inch	26 1X1X12	26 1X1X12
Fuse Current	A	3.15	3.15
Sound Pressure Level (SH/H/MH/M/ML/L/SL)	dB(A)	42/36/34/32/28/24/21	43/36/34/32/28/24/22
Sound Power Level (SH/H/MH/M/ML/L/SL)	dB(A)	52/46/44/42/38/34/31	53/46/44/42/38/34/32
Dimension of Outline (WXHXD)	inch	34X11 1/2X8 7/32	34X11 1/2X8 7/32
Dimension of Carton Box (LXWXH)	inch	37X11 7/64X14 23/32	37X11 7/64X14 23/32
Dimension of Package (LXWXH)	inch	37 1/8X11 43/64X14 5/6	37 1/8X11 43/64X14 5/6
Net Weight	lb	24.25	24.25
Gross Weight	lb	28.66	28.66
Liquid pipe	inch	Φ1/4	Φ1/4
Gas Pipe(to indoor unit)	inch	Φ1/2	Φ1/2

Note: The connection pipe applies metric diameter.

The above data is subject to change without notice; please refer to the nameplate of the unit.

Model		B-VFH18MC-1	B-VFH24MB-1
Product Code		CB148N07500_L61437	CB148N07600_L61437
Rated Voltage	V~	208/230	208/230
Rated Frequency	Hz	60	60
Phases		1	1
Cooling Capacity	Btu/h	18000(3412~22178)	24000(6824~29343)
Heating Capacity	Btu/h	19000(3412~23202)	25000(7506~37532)
Air flow volume (SH/H/MH/M/ML/L/SL)	CFM	559/512/465/418/371/330/282	647/589/530/471/412/353/294
Dehumidifying Volume	Pint/h	3.80	5.28
Fan Type		Cross-flow	Cross-flow
Diameter Length(DXL)	inch	Φ4X30 1/8	Φ4 1/6X35
Fan Motor Cooling Speed (SH/H/MH/M/ML/L/SL)	r/min	1400/1300/1200/1100/1000/900/800	1400/1300/1200/1100/1000/900/800
Fan Motor Heating Speed (SH/H/MH/M/ML/L/SL)	r/min	1450/1350/1250/1150/1050/950/850	1350/1350/1250/1150/1050/900/800
Output of Fan Motor	W	25	70
Fan Motor RLA	A	0.10	0.38
Fan Motor Capacitor	μF	/	/
Evaporator Form		Aluminum Fin-copper Tube	Aluminum Fin-copper Tube
Pipe Diameter	inch	Φ2/7	Φ2/7
Row-fin Gap	inch	2-1/17	2-1/17
Coil Length (LXDXW)	inch	30 2/17X1X13 1/2	35 5/9X1X15
Fuse	A	3.15	3.15
Sound Pressure Level (SH/H/MH/M/ML/L/SL)	dB (A)	51/47/44/41/38/36/33	52/49/47/45/43/41/38
Sound Power Level (SH/H/MH/M/ML/L/SL)	dB (A)	61/57/54/51/48/46/43	62/59/57/55/53/51/48
Dimension (WXHXD)	inch	40X12 5/9X9	46 3/8X12 5/6X10 2/5
Dimension of Carton Box (LXWXH)	inch	43X15 1/2X12 4/5	49X16 1/6X13 3/4
Dimension of Package (LXWXH)	inch	43 1/5X15 5/8X13 2/5	49 1/2X16 2/7X14 1/3
Net Weight	lb	30.9	38.6
Gross Weight	lb	38.6	47.4
Liquid Pipe	inch	Φ1/4	Φ1/4
Gas Pipe(to indoor unit)	inch	Φ5/8	Φ5/8
Note: The connection pipe applies metric diameter.			

The above data is subject to change without notice; please refer to the nameplate of the unit.

2.2 Noise Curve

B-VFH09MB-1/B-VFH12MB-1

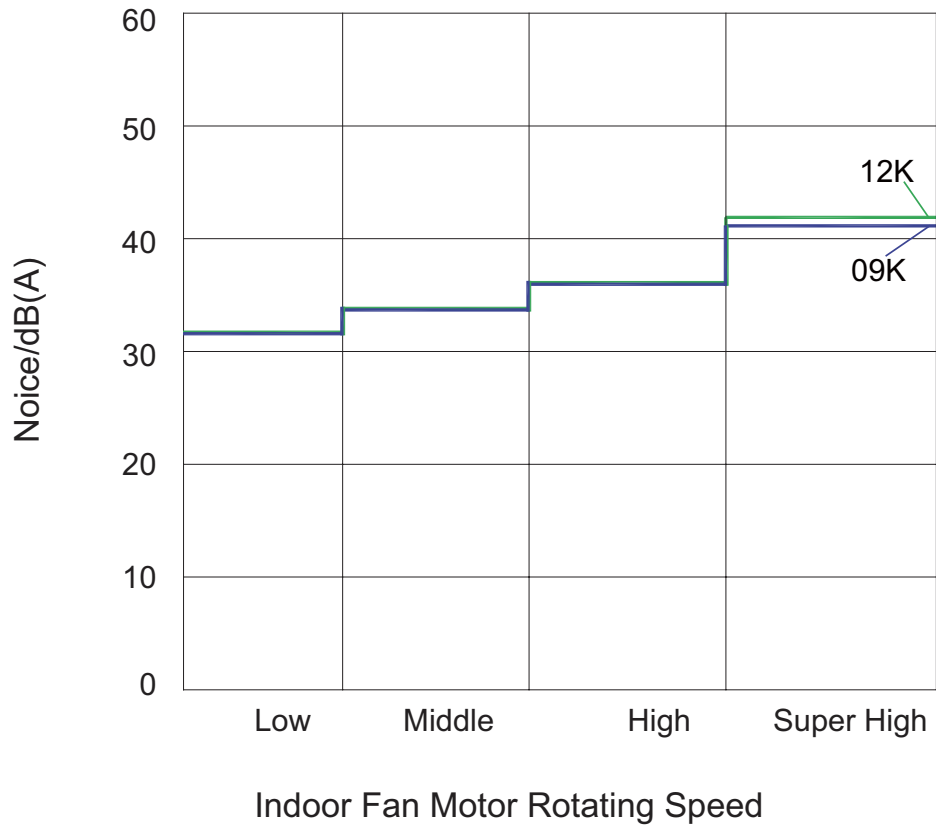

B-VFH18MC-1/B-VFH24MB-1

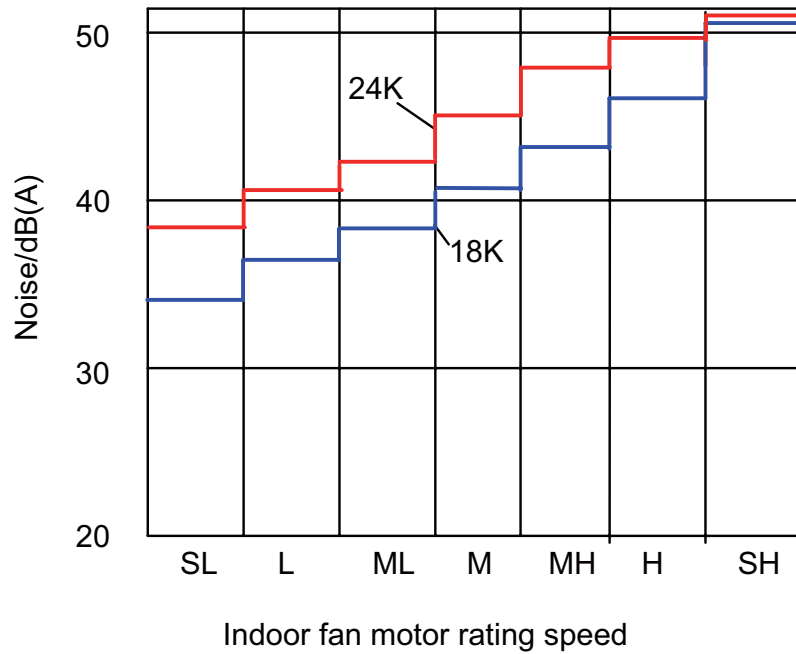

3. Outline Dimension Diagram

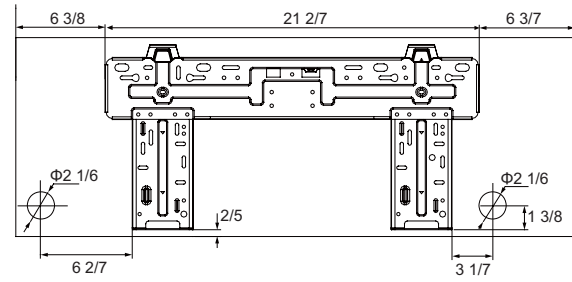
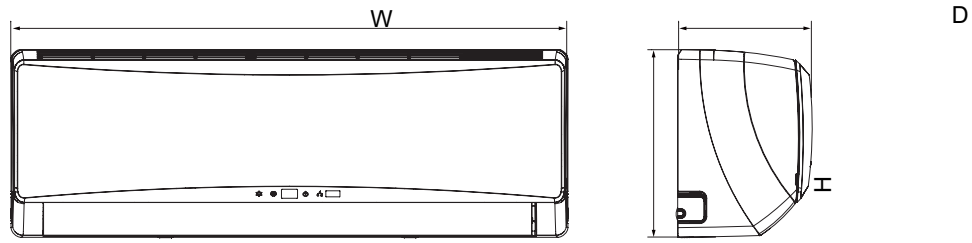

B-VFH09MB-1/B-VFH12MB-1

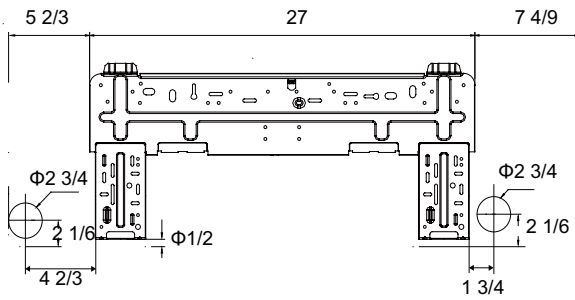

B-VFH18MC-1

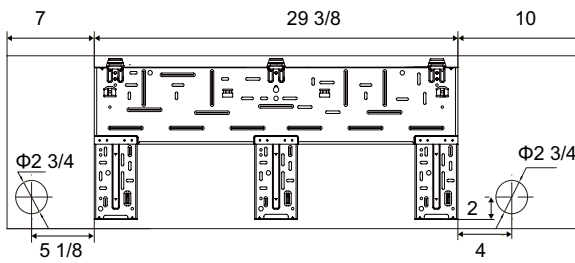

B-VFH24MB-1

Unit:inch

Model	W	H	D
B-VFH09MB-1/B-VFH12MB-1	34	11 1/2	8 7/32
B-VFH18MC-1	40	12 5/9	9
B-VFH24MB-1	46 3/8	12 5/6	10 2/5

4. Refrigerant System Diagram

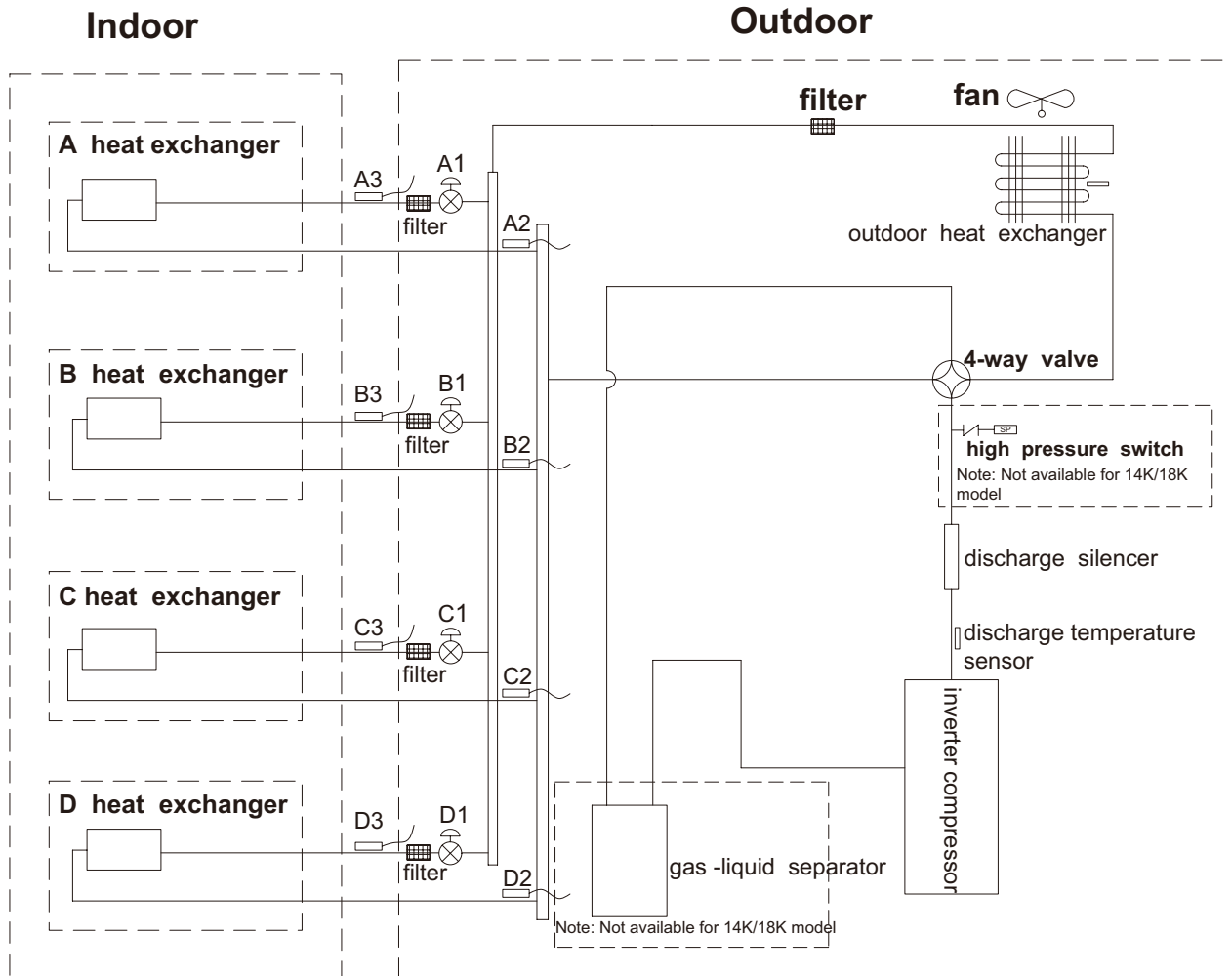

A1:A-unit electronic expansion valve B1:B-unit electronic expansion valve
C1:C-unit electronic expansion valve D1:D-unit electronic expansion valve
A2:A-unit gas pipe temperature sensor B2:B-unit gas pipe temperature sensor
C2:C-unit gas pipe temperature sensor D2:D-unit gas pipe temperature sensor
A3:A-unit liquid pipe temperature sensor B3:B-unit liquid pipe temperature sensor
C3:C-unit liquid pipe temperature sensor D3:D-unit liquid pipe temperature sensor

5. Electrical Part

5.1 Wiring Diagram

●Instruction

Symbol	Symbol Color	Symbol	Symbol Color	Symbol	Name
WH	White	GN	Green	CAP	Jumper cap
YE	Yellow	BN	Brown	COMP	Compressor
RD	Red	BU	Blue		Grounding wire
YEGN	Yellow/Green	BK	Black	/	/
VT	Violet	OG	Orange	/	/

Note: Jumper cap is used to determine fan speed and the swing angle of horizontal lover for this model.

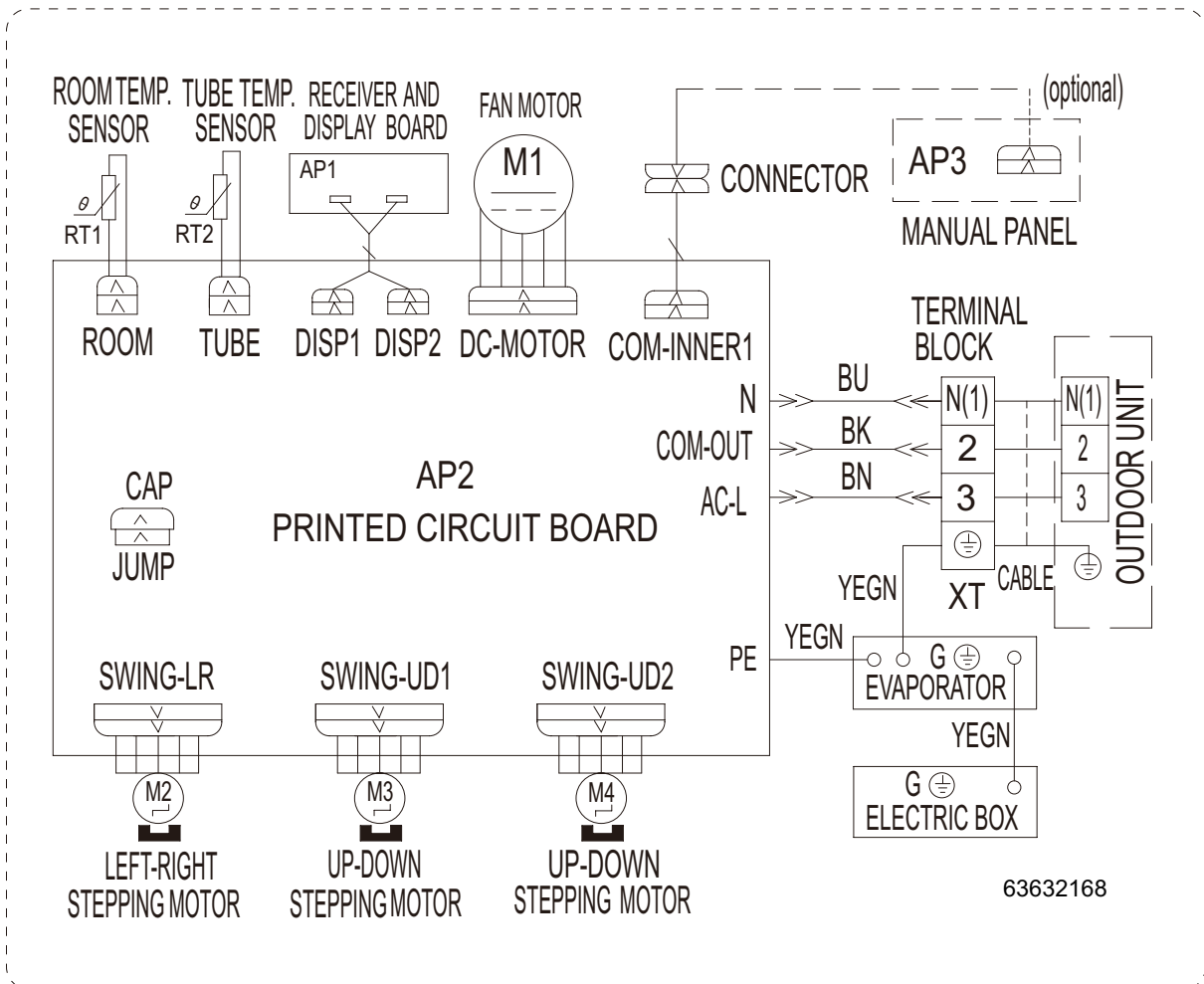

These wiring diagrams are subject to change without notice; please refer to the one supplied with the unit.

6. Function and Control

6.1 Remote Controller Introduction

Buttons on Remote Controller



(before opening cover)

- 1 ON/OFF button
- 2 FAN button
- 3 MODE button
- 4 +/- button



(after opening cover)

- 1 ON/OFF button
- 2 FAN button
- 3 MODE button
- 4 +/- button
- 5 TURBO button
- 6 button
- 7 button
- 8 CLOCK button
- 9 TIMER ON/TIMER OFF button
- 10 TEMP button
- 11 button
- 12 I FEEL button
- 13 LIGHT button
- 14 X-FAN button
- 15 QUIET button
- 16 SLEEP button

Introduction for Icons on Display Screen

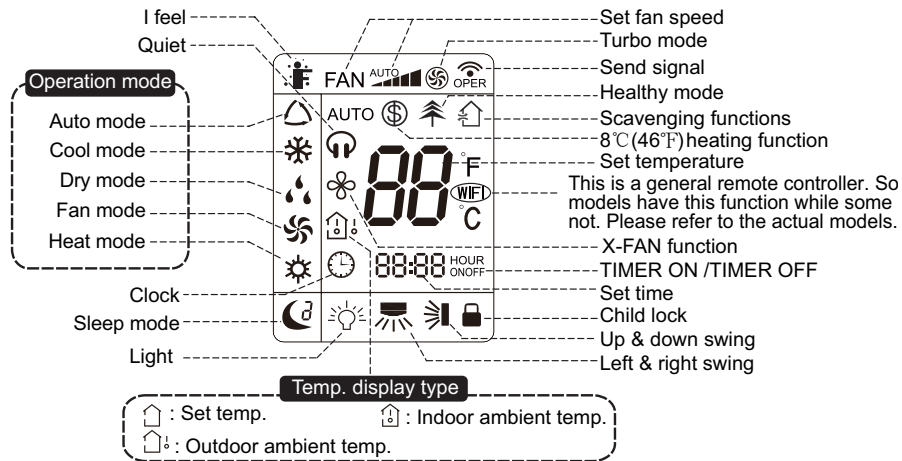

Introduction for Buttons on Remote Controller

Note:

- This is a general use remote controller, it is used for air conditioners with multifunction; For some functions, which the model doesn't have, if pressing the corresponding button on the remote controller, the unit will keep the original running status.
- After applying power, the air conditioner will emit a sound. When operation indicator " " is ON (red indicator), you can operate the air conditioner by using remote controller.
- Under on status, pressing the button on the remote controller, the signal icon " " on the display of remote controller will blink once and the air conditioner will emit a sound, which means the signal has been sent to the air conditioner.
- Under off status, set temperature and clock icon will be displayed on the display of remote controller (If timer on, timer off and light function are set, the corresponding icons will be displayed on the display of remote controller at the same time); Under on status, the display will show the corresponding set function icons.

1. ON/OFF button

Press this button and the unit will turn on; press it once more and the unit will turn off. Sleep function will be canceled when unit is off.

2. FAN button

Press this button, Auto, Low, Medium-low, Medium, Medium-high, High speed can be circularly selected. After powered on, Auto fan speed is default. Under DRY mode, Low fan speed only can be set up.

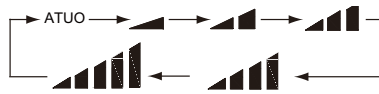

Note: Dry mode is Low fan speed only.

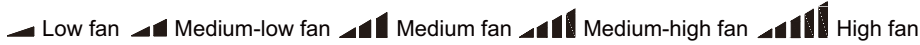

3. MODE button

Press this button, Auto, Cool, Dry, Fan, Heat mode can be selected circularly. Auto mode is default while powered on. Under Auto mode, the temperature will not be displayed; Under Heat mode, the initial value is 28°C (82°F); Under other modes, the initial value is 25°C (77°F).

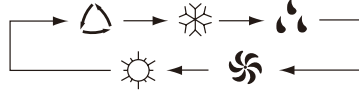

+/- button

- Presetting temperature can be increased.
Press this button, the temperature can be set up, continuously press this button and hold for two seconds, the relative contents will quickly change, until releasing this button. The temperature adjustment is unavailable under Auto mode.
- Presetting temperature can be decreased.
Press this button, the temperature can be set up, continuously press this button and hold for two seconds, the relative contents will quickly change. The temperature adjustment is unavailable in the Auto mode.
- **TURBO button**
Under Cool or Heat mode, press this button can turn on or turn off the Turbo function. After the Turbo function turned on, the signal of Turbo will display. The signal will be automatically cancelled if changing the mode or fan speed.
- **Swing button**
Press this button to set left & right swing angle cycling as below:

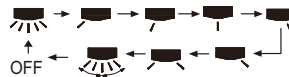

7. Guide Louver button

Press this button will set swing angle, which circularly changes as below:



This remote controller is universal. If it receives three kinds of following status, the swing angle will remain original.



If guide louver is stopped when it is swinging up and down, it will remain its present position.

The icon indicates guide louver swings back and forth in the five positions, as shown in the figure.

8. CLOCK button

Press this button, the clock can be set up, signal (clock icon) blink and display. Within 5 seconds, the value can be adjusted by pressing + or - button, continuously press this button for 2 seconds above, every 0.5 seconds, the value increases. While blinking, re-press the Clock button or Confirm button, signal (clock icon) will be constantly displayed and it denotes the setting succeeded. Ten minutes after powered on, 12:00 is defaulted to display and signal (clock icon) will be displayed. If there is signal (clock icon) displayed, that denotes the current time value is Clock value, otherwise is Timer value.

9. TIMER ON/TIMER OFF button

- Timer On setting: Signal "ON" will blink and display, signal (clock icon) will disappear, the numerical section will become the timer on setting status. During 5 second blink, press + or - button to adjust the time value of numerical section. Every press of that button, the value will be increased or decreased one minute. Hold + or - button, 2 seconds later, it quickly changes, the way of change is: During the initial 2.5 seconds, ten number change in the one place of minute, then the one place is constant, ten numbers change in the ten place of minute at 2.5 seconds speed and carry. During 5s blink, press the Timer button, the timer sets. The Timer On has been set up, re-press the timer button, the Timer On will be canceled. Before setting the Timer, please adjust the Clock to the current actual time.
- Press this key to enter into TIMER OFF setup, the TIMER OFF icon will blink. The method of setting is the same as TIMER ON.

10. TEMP button

Press this button, you will see indoor set temperature, indoor ambient temperature or outdoor ambient temperature on indoor unit's display. The setting on remote controller is selected circularly as below:



When selecting "🏠" with remote controller or no display, temperature indicator on indoor unit displays set temperature; when selecting "🏠" with remote controller, temperature indicator on indoor unit displays indoor ambient temperature; when selecting "🏠!" with remote controller, temperature indicator on indoor unit displays outdoor ambient temperature. Three seconds later it will return to the setting temperature.

Attention: When displaying the outdoor ambient, the displaying range is 32-99°F and 0-60°C. When it goes beyond range, it keeps the threshold data (the smallest—0°C or 32°F and the largest 99°F or 60°C).

Warm tips: When operating buttons on the cover please make sure the cover is closed completely.

11. 🏠 / 🏠 button (This function is only available for some models)

Press this button to achieve the on and off of healthy function in operation status. Press this button for the first time to start scavenging function; LCD displays "🏠". Press the button for the second time to start healthy and scavenging functions simultaneously; LCD displays "🏠" and "🏠". Press this button for the third time to quit healthy and scavenging functions simultaneously. Press the button for the fourth time to start healthy function; LCD display "🏠". Press this button again to repeat the operation above.

12. I FEEL button

Press this button once, to turn on the I FEEL function, then the figure of "I FEEL" will be displayed, after every press of other function button, every 200ms to send I FEEL once, after this function started, the remote control will send temperature to the main unit every 10 minutes. Press this button again, this function will be turned off.

13. LIGHT button

Press this button at unit On or Off status, Light On and Light Off can be set up. After powered on, Light On is default.

14. X-FAN button

Pressing X-FAN button in COOL or DRY mode, the icon 🌀 is displayed and the indoor fan will continue operation for two minutes in order to dry the indoor unit even though you have turned off the unit. After energization, X-FAN OFF is defaulted. X-FAN is not available in AUTO, FAN or HEAT mode.

15. QUIET button

Press this button, the Quiet status is under the Auto Quiet mode (display "🔇" and "Auto" signal) and Quiet mode (display "🔇" signal) and Quiet OFF (there is no signal of "🔇" displayed), after powered on, the Quiet OFF is defaulted. Under the Quiet mode (Display "🔇" signal), the fan speed is not available.

16. SLEEP button

- Press this button to select Sleep 1 (🌙¹), Sleep 2 (🌙²), Sleep 3 (🌙³) and cancel Sleep.
- Sleep 1 is Sleep mode 1, in Cool, Dehumidify modes: sleep status after running for one hour, the main unit setting temperature will increase 1°C (1°F~2°F), two hours, setting temperature increased 2°C (3°F~4°F), the unit will run at this setting temperature. In Heat mode: sleep status after running for one hour, the setting temperature will decrease 1°C (1°F~2°F), two hours, setting temperature will decrease 2°C (3°F~4°F), then the unit will run at this setting temperature.
- Sleep 2 is sleep mode 2. The air conditioner will run according to the presetting a group of sleep temperature curve.
In Cool mode:
 - 1) When setting the initial temperature 16~23°C (61°F~74°F), after turning on Sleep function, the temperature will be increased 1°C (1°F~2°F) every hour, after 3°C (5°F~6°F) the temperature will be maintained, after seven hours, the temperature will be decreased 1°C (1°F~2°F), after that the unit will keep running at this temperature;
 - 2) When setting the initial temperature 24~27°C (75°F~81°F), after turned on Sleep function, the temperature will be increased 1°C (1°F~2°F) every hour, after 3°C (3°F~4°F) the temperature will be maintained, after seven hours, the temperature will be decreased 1°C (1°F~2°F), after that the unit will run at this temperature;
 - 3) When setting the initial temperature 28~29°C (82°F~85°F), after turned on Sleep function, the temperature will be increased 1°C (1°F~2°F) in every hour, after 1°C (1°F~2°F) the temperature will be maintained, after seven hours, the temperature will be decreased 1°C (1°F~2°F), after that the unit will run at this temperature;
 - 4) When setting the initial temperature 30°C (86°F), at this temperature setting, after seven hours, the temperature will be decreased 1°C (1°F~2°F), after that the unit will run at this temperature;In Heat mode:
 - 1) Under the initial presetting temperature 16°C (61°F), it will maintain this setting temperature.
 - 2) Under the initial presetting temperature 17~20°C (62°F~68°F), after Sleep function start up, the temperature will decrease 1°C (1°F~2°F) every hour, after 1°C (1°F~2°F) decreased, this temperature will be maintained.
 - 3) Under the initial presetting temperature 21~27°C (69°F~82°F), after Sleep function start up, the temperature will decrease 1°C (1°F~2°F) every hour, after 2°C (3°F~4°F) decreased, this temperature will be maintained.
 - 4) Under the initial presetting temperature 28~30°C (82°F~86°F), after Sleep function start up, the temperature will decrease 1°C (1°F~2°F) every hour, after 3°C (5°F~6°F) decreased, this temperature will be maintained.

- Sleep 3—the sleep curve setting under Sleep mode by DIY:
 - 1) Under Sleep 3 mode, press and hold "Turbo" button, remote control enters into sleep setting status, the time of remote control will display "1 hour", the temperature setting screen will display the corresponding temperature of last setting sleep curve and blink (The first entering will display according to the initial curve setting value from factory).
 - 2) Adjusting "+" and "-" button will change the corresponding temperature setting, after adjusted, press "Turbo" button for confirmation.
 - 3) At this time, hour will be automatically increased at the timer position on the remote control, the place of temperature setting screen will display the corresponding temperature of last sleep curve setting and blink.
 - 4) Repeat the above step (2)~(3) operation, until 8 hours temperature setting is finished and sleep curve setting is finished. At this time, the remote control will resume the original timer display; temperature display will return to original temperature setting.
- Sleep 3—the sleep curve setting under Sleep mode can be checked:
Use the above method to inquire the presetting sleep curve, enter into user individualization sleep setting status, but do not change the temperature, press "Turbo" button for confirmation.
Note: In the above presetting or inquiry procedure, if button is not pressed for 10 seconds, the sleep curve setting status will automatically stop and resume the original display. In the presetting or inquiry procedure, press "ON/OFF" button, "Mode" button, "Timer" button or "Sleep" button, the sleep curve setting or inquiry status will stop similarly.

17. X-FAN function

This function indicates that moisture on evaporator or indoor unit will be blow-dried after the unit is stopped to avoid mold.

1. Having set X-FAN function on: After turning off the unit by pressing ON/OFF button indoor fan will continue running for about 2 minutes at low speed. In this period, press X-FAN button to stop indoor fan directly.
2. Having set X-FAN function off: After turning off the unit by pressing ON/OFF button, the complete unit will be off directly.

18. AUTO RUN

When AUTO RUN mode is selected, the setting temperature will not be displayed on the LCD, the unit will be in accordance with the room temperature automatically to select the suitable running method and to make ambient comfortable.



19. Turbo function

Start this function, the unit will run at super-high fan speed to cool or heat quickly so that the ambient temperature approaches the preset temperature as soon as possible.



20. Lock

Press + and - buttons simultaneously to lock or unlock the keyboard. If the remote controller is locked, the icon  will be displayed on it, in which case, press any button, the mark will flicker three times. If the keyboard is unlocked, the mark will disappear.

21. Swing up and down

- 1) Press swing up and down button continuously for more than two seconds, the main unit will swing back and forth from up to down, and then release the button, the unit will stop swinging and present position of guide louver will be kept.
- 2) Under swing up and down mode, when the status is switched from off to , if the button is pressed two seconds later,  status will switch to off status directly; if the button is pressed again with two seconds, the change of swing status will also depend on the circulation sequence stated above.

22. Swing left and right

- 1) Press swing left and right button continuously more than two seconds, the main unit will swing back and forth from left to right, and then release the button, the unit will stop swinging and present position of guide louver will be kept immediately.
- 2) Under swing left and right mode, when the status is switched from off to , press this button again two seconds later,  status will switch to off status; press this button again within two seconds, the change of swing status will also depend on the circulation sequence stated above.

23. Switch between Fahrenheit and Centigrade

Under status of unit off, press MODE and - buttons simultaneously to switch °C and °F.

24. Combination of "TEMP" and "CLOCK" buttons: About Energy-saving Function

Press "TEMP" and "CLOCK" simultaneously in COOL mode to start energy-saving function. Screen on the remote controller displays "SE". Repeat the operation to stop the function.

25. Combination of "TEMP" and "CLOCK" buttons: About 8°C (46°F) Heating Function

Press "TEMP" and "CLOCK" simultaneously in HEAT mode to start 8°C(46°F) Heating Function. Screen on the remote controller displays "8" and a selected temperature of "8°C" (46°F if Fahrenheit is adopted). Repeat the operation to stop the function.

26. Auto Quiet function

When auto quiet function is selected:

- 1) Under cooling mode: indoor fan operates at notch 4 speed. 10 minutes later or when indoor ambient temperature $\leq 28^{\circ}\text{C}$ (82°F), indoor fan will operate at notch 2 speed or quiet mode according to the comparison between indoor ambient temperature and set temperature.
- 2) Under heating mode: indoor fan operates at notch 3 speed or quiet mode according to the comparison between indoor ambient temperature and set temperature.
- 3) Under dry, fan mode: indoor fan operates at quiet mode.
- 4) Under auto mode: the indoor fan operates at the auto quiet mode according to actual cooling, heating or fan mode.

27. Sleep function

Under the Fan and Auto mode, the Sleep function cannot be set up. Under Dehumidify mode, only Sleep 1 can be selected. Select and enter into any kind of Sleep mode, the Quiet function can be entered, different Quiet status is optional.

Operation Guide

1. General operation

- 1) After powered on, press ON/OFF button, the unit will start to run. (Note: When it is powered on, the guide louver of main unit will close automatically.)
- 2) Press MODE button, select desired running mode.
- 3) Pressing + or - button, to set the desired temperature (It is unnecessary to set the temp. at AUTO mode.)
- 4) Pressing FAN button, set fan speed, can select AUTO FAN, LOW, MEDIUM-LOW, MEDIUM, MEDIUM-HIGH and HIGH.
- 5) Press button to select the swing.

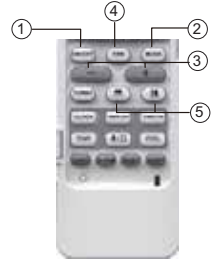

2. Optional operation

- 1) Press SLEEP button to set sleep.
- 2) Press TIMER ON and TIMER OFF button, can set the scheduled timer on or timer off.
- 3) Press LIGHT button, to control the on and off of the displaying part of the unit (This function may not be available for some units).
- 4) Press TURBO button, can realize the ON and OFF of TURBO function.



Replacement of Batteries in Remote Controller

- 1) Press the back side of remote controller marked with "⊞", as shown in the fig, and then push out the cover of battery box along the arrow direction.
- 2) Replace two 7# (AAA 1.5V) dry batteries, and make sure the position of "+" pole and "-" pole are correct.
- 3) Reinstall the cover of battery box.

Note:

- During operation, point the remote control signal sender at the receiving window on indoor unit.
- The distance between signal sender and receiving window should be no more than 25 ft, and there should be no obstacles between them.
- Signal may be interfered with easily where there are fluorescent lamps or wireless telephones; remote controller should be close to indoor unit during operation.
- Replace new batteries of the same model when replacement is required.
- When you do not use remote controller for a long time, please take out the batteries.
- If the display on remote controller is fuzzy or there is no display, please replace batteries.

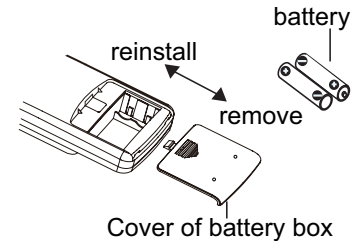

6.2 Brief Description of Modes and Functions

Basic mode

Cooling; Drying; Heating; Auto; Fan.

1. Cooling mode

- 1) Under cooling mode, fan and swing operate at setting status. Temperature setting range is 16~30°C (61°~86°F).
- 2) During malfunction of outdoor unit or when stopping operation due to fault protection, indoor unit keeps original operation status and the corresponding malfunction code will be displayed.
- 3) Indoor fan stops operation during mode change.

2. Drying mode

- 1) Under drying mode, fan operates at low speed and swing operates at setting status. Temperature setting range is 16~30C (61F~86F).
- 2) During malfunction of outdoor unit or when stopping operation due to fault protection, indoor unit keeps original operation status and the corresponding malfunction code will be displayed.
- 3) Protection status is same as that under cooling mode.

3. Heating mode

- 1) Under heating mode, temperature setting range is 16~30°C (61°F~86°F).
- 2) Operating condition and process for heating mode:
After turning on the unit under heating mode, indoor unit operates according to cold air prevention condition; During heating process , after room temperature is increased to set temperature, the complete unit stops operation. Indoor fan will blow residual heat and delay one minute to stop operation.
During heating operation, after turning off the unit by remote controller, indoor fan will blow residual heat to delay 10 seconds to top operation.
- 3) Protection function
When compressor stops operation due to malfunction (include malfunction of temperature sensor) during heating mode, indoor fan will blow residual heat to delay 1min to stop operation.
- 4) Oil return and defrosting
After receiving defrosting signal from outdoor unit or oil return signal, the complete unit enters into defrosting mode. Meanwhile, heat ing icon on indoor unit will be OFF 0.5s and ON 10s.

4. Auto mode

- 1) Operating condition and process for auto mode
Under this mode, system will select operation mode (cooling, heating, fan) automatically according to the change of indoor ambient t emperature. Allow 30 seconds auto delay protection for mode switchover.
◆ When indoor ambient temperature is $\geq 26^{\circ}\text{C}$ (79°F), the system operates under cooling mode. Meanwhile, ex-factory setting temperature is fixed at (79°F), the system operates under cooling mode. Meanwhile, ex-factory setting temperature is fixed at 25°C (77°F) [(Tfix=25°C (77°F)].
◆ For heat pump unit: When indoor ambient temperature is $\leq 21^{\circ}\text{C}$ (69°F), the system operates under heating mode. Meanwhile, ex-factory setting temperature is fixed at 20°C (68°F) [Tfix=20°C (68°F)].
◆ When 21°C (69°F) < T indoor ambient temperature is < 26°C (79°F): The system operates under fan mode when turning on the unit in auto mode; the system keeps previous operation mode when the unit operates at auto mode switched from cooling, heating or fan mode; the system operates at fan mode when the unit operates at auto mode switched from dry mode.
- 2) Display: operation icon, actual operation mode icon. Display set temperature, but cannot be adjusted.
- 3) Protection function is same as that under other modes. (refer to the section of system function protection)

5. Fan mode

In fan mode, indoor fan operates at set fan speed, while compressor and outdoor fan stops operation. 4-way valve is de-energized. Temperature setting range is 16~30°C (61°F~86°F).

Other controls

1. Buzzer

Upon energization or pressing button or receiving signal from remote controller, the buzzer will beep.

2. Auto button

When pressing this button under OFF status, the complete unit will operate under auto mode and indoor unit will operate at auto fan speed. Swing mode will operate when indoor fan is operating.

Press this button under ON status to turn off the unit.

a. Up and down swing

After energization, small and big horizontal louvers will rotate in a counterclockwise direction to close the air outlet. When turning on the unit, if up and down swing function has not been set by remote controller, small and big horizontal louvers will rotate in a clockwise direction at the fixed direction; if up and down swing function has been set by remote controller, small and big horizontal louvers will operate at the status set by remote controller.

The small horizontal louver only operates under heating mode. Under other mode, the small horizontal louver always stays at the closed status;

On the 9k/12k model, the small horizontal louver will start operation only when the big horizontal louver rotates to the second fixed angle (62°) under heating mode.

On the 18k model, the small horizontal louver will start operation only when the big horizontal louver rotates to the first fixed angle (63°) under heating mode.

On the 24k model, the small horizontal louver will start operation only when the big horizontal louver rotates to the first fixed angle (40°) under heating mode.

When small and big horizontal louvers receive the signal of canceling up and down swing function from remote controller during swing process, small and big horizontal louvers will stop at current position. After turning off the unit, small and big horizontal louvers will rotate in a counterclockwise direction to close air outlet.

b. Left and right swing

After energization, the vertical louver will operate at the start position and then stop at the middle position. When turning on the unit, if left and right swing function has not been set by remote controller, the horizontal louver will stop at middle position; if the left and right swing function has been set by remote controller, the vertical louver will operate at the swing status set by remote controller. When the vertical louver receives the signal to cancel left and right swing function from remote controller, the horizontal louver will stop at the current position.

After turning off the unit, the horizontal louver stops at original position.

3. Auto fan

a. Auto fan speed under heating mode

When $T_{amb.} < T_{preset} - 3^{\circ}\text{C}$ (5°F~6°F), indoor fan operates at high speed;

When $T_{preset} - 3^{\circ}\text{C}$ (5°F~6°F) $\leq T_{amb.} < T_{preset} + 2^{\circ}\text{C}$ (3°F~4°F), indoor fan operates at medium speed; When $T_{preset} + 2^{\circ}\text{C}$ (3°F~4°F) $\leq T_{amb.} < T_{preset} + 4^{\circ}\text{C}$ (7°F~8°F), indoor fan operates at low speed;

When $T_{amb.} \geq T_{preset} + 4^{\circ}\text{C}$ (7°F~8°F) indoor fan operate at quiet mode.

b. Auto fan speed under cooling or heating mode

When $T_{amb.} \geq T_{preset} + 3^{\circ}\text{C}$ (5°F~6°F), indoor fan operates at high speed;

When $T_{preset} < T_{amb.} < T_{amb.} + 3^{\circ}\text{C}$ (5°F~6°F), indoor fan operates at medium speed;

When $T_{preset} - 2^{\circ}\text{C}$ (3°F~4°F) $< T_{amb.} \leq T_{preset}$, indoor fan operates at low speed;

When $T_{amb.} \leq T_{preset} - 2^{\circ}\text{C}$ (3°F~4°F), indoor fan operate at quiet mode;

c. The default auto fan speed is low speed under dry mode

In addition:

1. During operation of auto fan speed, there should be at least 3min and 30s operation time during fan speed switchover.
2. Under auto fan mode, quiet fan speed is valid.

4. Sleep

Sleep mode is only valid under cooling mode and heating mode;

Cooling mode: Basing on the set temperature of remote controller, after turning on the sleep function for a few hours, set temperature will increase automatically according to human body's comfort.

Heating mode: Basing on the set temperature of remote controller, after turning on the sleep function for a few hours, set temperature will decrease automatically according to human body's comfort.

5. Timer function

Controller operates general timer function and clock timer function simultaneously. When selecting the remote controller with general timer, you can only activate the general timer function of controller; when selecting the remote controller with clock timer, you can only activate the clock timer function of controller.

1) General timer

Timer precision for general timer is 0.5 hour, to 24 hours circulating timer can't be set.

- ◆ Timer ON can be set at unit OFF. If selected ON time is reached, the system will start to operate according to previous setting status by remote controller. Time setting range is 0.5-24hr in 30-minute increments.
- ◆ Timer OFF can be set at unit ON. If selected OFF time is reached, the unit will stop operation. Time setting range is 0.5-24 hr in 30-minute increments.

2) Clock timer

Timer precision for clock timer is 1 min, and 24 hours circulating timer can be set.

- ◆ Timer ON: If timer ON is set during operation of the unit, the unit will continue to operate. If timer ON is set at unit OFF, when reaching ON time the unit will start to operate according to previous setting status by remote controller.
- ◆ Timer OFF: If timer OFF is set at unit OFF, the system will keep OFF status. If timer OFF is set at unit ON, upon reaching OFF time, the unit will stop operation.
- ◆ Timer change

Under timer status of system, you can set timer ON and timer OFF by pressing ON/OFF button on remote controller. You can also set timer setting again and the system will operate according to the last setting status.

If timer ON and timer OFF are set at the same time during operation of the unit, the unit will keep operating at current status until reaching OFF time. When reaching ON time, the unit will turn on automatically. The unit will repeat this pattern every 24 hours.

If timer ON and timer OFF are set at the same time in OFF status, the unit will remain OFF until reaching ON time. When reaching OFF time, the unit will be turned off automatically. The unit will repeat this pattern every 24 hours.

If timer ON and timer OFF are the same, OFF command will prevail.

6. Memory function

1) Power-off memory when turning on the unit

◆ Memory content: ON status; mode; swing status; light; set temperature; set fan speed; general timer; Fahrenheit/Centigrade.

2) Power-off memory when turning Off unit

◆ Memory content: OFF status; mode; swing status; light; set temperature; set fan speed; general timer; Fahrenheit/Centigrade.

7. Electrostatic dedust function

During operation of indoor fan, press healthy button on remote controller (if there's no healthy button, it defaulted that the healthy function is ON) to start up electrostatic dedust function.

When the fan stops operation, the electrostatic dedust function will be turned off.

8. I FEEL function

When I FEEL command is received, the controller will operate according to the ambient temperature sent by the remote controller (For defrosting and cold blow prevention, the unit operates according to the ambient temperature sensed by the air conditioner). The remote controller will regularly send ambient temperature data to the controller. When the data has not been received, the controller will operate according to the temperature sensed by the air conditioner. If I FEEL function hasn't been started, the ambient temperature will be that sensed at the air conditioner.

9. Reserve Fahrenheit display function

If requested to display indoor ambient temperature, indoor ambient temperature sent by remote controller will display.

Temperature range is 0~60°C (32~99°F). Display will show the set temperature as default. After displaying ambient temperature for 3s, or receiving other valid remote control signal within 3s, the unit display will return to set temperature.

10. Indoor and outdoor ambient temperature display function

If requested to display indoor and outdoor ambient temperature, indoor unit will display corresponding ambient temperature according to indoor or outdoor ambient signal sent by remote controller. Temperature display range is 0~60°C (if ambient temperature value exceeds this range, the temperature will be displayed at the upper or lower limit). After ambient temperature is displayed for 3s, it will display set temperature.

11. Turbo function

When indoor unit receives turbo function from remote controller, indoor fan operates at super-high fan speed; outdoor fan operates at turbo function in cooling or heating mode.

12. Compulsory defrosting function

1) Start up compulsory defrosting function

Under ON status, set heating mode with remote controller and adjust the temperature to 16°C(61°F). Press "+, -, +, -, +,-" button successively within 5s and the complete unit will enter into compulsory defrosting status. Meanwhile, heating indicator on indoor unit will cycle ON 10s and OFF 0.5s successively. (Note: If complete unit has malfunction or stops operation due to protection, compulsory defrosting function can be started up after malfunction or protection is reset.

2) Exit compulsory defrosting mode

After compulsory defrosting is started up, the unit will exit defrosting operation according to the actual defrost termination criteria, and the unit will resume normal heating operation.

13. Refrigerant recovery function (applicable for moving the unit or maintaining the unit)

1) Start up refrigerant recovery function

Set cooling mode with remote controller within 5 min after energization, adjust temperature at 16°C(61°F) and press light button on remote controller 3 times successively at any one indoor unit within 3s and then the unit will enter into refrigerant recovery status. All indoor units display Fo. Maintenance person close all liquid valves. After 5min, slightly depress the schrader valves with tools one by one. If no refrigerant sprays out, close corresponding valve immediately, turn off the unit with remote controller and then remove the connection pipe.

2) Exit refrigerant recovery function

During refrigerant recovery process, if any one indoor unit receives any remote control signal or refrigerant recovery function operates for about 25 min, refrigerant recovery function will be exited automatically. If the unit is at standby status before refrigerant recovery, the unit will remain in standby status after refrigerant recovery. If the unit is at ON status, the unit will operate according to original operation mode.

3) After entering refrigerant recovery function: Indoor unit operates at cooling mode. Fan speed is super-high speed and set temperature is 16°C (61°F). Horizontal will open at the minimum operation angle.

14. Dry and mildew-proof function

After setting dry function with remote controller under cooling or drying mode and then turning off the unit, indoor fan will delay 2 min to dry the fan and coil. Horizontal louver will stop at horizontal position.

16.8°C (46°F) heating function (this function is realized by setting 8°C (46°F) heating signal with remote controller. Please refer to corresponding part of remote controller in instruction manual).

8°C (46°F) heating function is only valid under heating mode. After setting is accomplished, indoor unit displays 8°C (46°F). Turbo function cannot be set after setting 8°C (46°F) heating function. Fan speed is adjusted according to below condition:

When Tindoor amb. ≤ Tpreset + 1°C (1°F~2°F), indoor fan operates at high speed;

When Tpreset + 1°C (1°F~2°F) < Tindoor amb. < Tpreset + 3°C (5°F~6°F), indoor fan operate at medium speed;

When Tindoor amb. ≥ Tpreset + 3°C (5°F~6°F), indoor fan operates at low speed; There should be at least 3 min and 30 s operation time for the switchover between high speed, medium speed and low speed.

8°C (46°F) heating mode cannot coexist with sleeping mode (realized by remote controller). Eg: When you have set 8°C (46°F) heating mode, if you then set sleep mode with remote controller, 8°C (46°F) heating mode will be canceled and the unit operates in sleep mode. Meanwhile, the set temperature value is the set temperature before entering into 8°C (46°F) heating mode. When you have set sleep mode, if you then set 8°C (46°F) heating mode with remote controller, sleep mode will be canceled and the unit will operate under 8°C (46°F) heating mode.

Other protections are the same as that under heating mode.

15. Comfortable and energy-saving function (this function is accomplished by setting energy-saving function with remote controller). Please refer to corresponding part of remote controller in instruction manual.

Comfortable and energy-saving function is only valid under cooling mode. After setting is accomplished, set temperature of indoor unit is 27°C (81°F), and indoor unit displays "SE".

After setting is accomplished and compressor operates, fan speed is adjusted automatically according to below conditions:

When Tamb. ≥32°C (90°F), indoor fan operates at super-high speed;

When 32°C (90°F) > Tamb. ≥ Tpreset + 2°C (3°F~4°F), indoor fan operates at high speed;

When Tpreset < Tamb. < Tpreet + 2°C (3°F~4°F), indoor fan operates at medium speed;

When Tamb. ≤ Tpreset, indoor fan operates at low speed.

After setting is accomplished, indoor fan operates at low speed when compressor stops operation.

There should be at least 3 min and 30 s operation time between high speed, medium speed and low speed.

After entering into energy-saving mode and When Tamb. ≥28°C(82°F) , horizontal louver operates at fixed-angle position 4.10 min later or Tamb. <28°C (82°F) or after receiving the changing order for swing angle, horizontal louver will operate at the angle set by remote controller. Other protections are the same as that under cooling mode.

If setting energy-saving function again under energy-saving mode, it will exit energy-saving mode.

16. Mode conflict

When indoor unit under operation, if start up other indoor unit and the setting mode is inconsistent with that indoor unit, mode conflict will occur. The indoor with mode conflict displays "E7" and indoor fan stops operation. Corresponding relationship for mode conflict and operation status after conflict is as below:

Mode relationship table for mode conflict:

Mode		Indoor unit with mode conflict	Operation status after mode conflict	
Indoor unit A	Indoor unit B		Indoor unit A	Indoor unit B
Cooling/drying	heating	Indoor unit B	Cooling/drying	Indoor fan stops operation
Heating	Cooling, drying, fan	Indoor unit B	Heating	Indoor fan stops operation
Fan	Heating	Indoor unit A	Indoor fan stops operation	Heating

Note:

(1) Indoor unit A: The indoor unit under operation currently.

(2) Indoor unit B: The indoor unit is turned on later

(3) If setting auto mode with remote controller, the unit will judge according to actual operation mode under auto mode.

Part II : Installation and Maintenance

7. Notes for Installation and Maintenance

Safety Precautions:

Important!

Please read the safety precautions carefully before installation and maintenance.

The following contents are very important for installation and maintenance.

Please follow the instructions below.

- The installation or maintenance must accord with the instructions.
- Comply with all national electrical codes and local electrical codes.
- Pay attention to the warnings and cautions in this manual.
- All installation and maintenance shall be performed by licensed contractor or qualified person.
- All electric work must be performed by a licensed technician according to local regulations and the instructions given in this manual.
- Be cautious during installation and maintenance. Prohibit incorrect operation to prevent electric shock, casualty and other accidents.



Warnings

Electrical Safety Precautions:

1. Cut off the power supply of air conditioner before service and maintenance.
2. The air conditioner must connect to a dedicated circuit and not share the same circuit with other appliances.
3. The air conditioner should be installed in a suitable location.
4. Make sure each wiring terminal is connected firmly during installation and maintenance.
5. Have the unit adequately grounded. The grounding wire can't be used for other purposes.
6. Must apply protective accessories such as protective boards, cable-cross loops and wire clips.
7. The live wire, neutral wire and grounding wire of power supply must correspond to the live wire, neutral wire and grounding wire of the air conditioner.
8. The power cord and power connection wires should not be pinched by hard objects.

9. If power cord or connection wire is broken, it must be replaced by a qualified person.
10. A disconnect switch must be installed in the circuit. The disconnect switch should be all-pole parting and the contact parting distance should be more than 3mm.
11. Make sure all wires and pipes are connected properly and the valves are opened before energizing.
12. Check if there is electric leakage on the unit body. If yes, please eliminate the electric leakage.
13. Replace the fuse with a new one of the same specification if it is burnt; don't replace it with a copper wire or conducting wire.

Installation Safety Precautions:

1. Select the installation location according to the requirements of this manual.(See the requirements in installation section)
2. Handle unit transportation with care; the unit should not be carried by only one person if it is more than 40 lbs.
3. When installing the indoor unit and outdoor unit, a sufficient mounting method must be used; make sure the installation support is firm.
4. Wear safety harness if the height of working is above six feet.
5. Use supplied components or recommended components during installation.
6. Make sure no foreign objects are left in the unit after finishing installation.

Refrigerant Safety Precautions:

1. Avoid contact between refrigerant and fire as it generates poisonous gas.
2. Apply specified refrigerant only. Never mix with any other refrigerant. Never leave air in the refrigerant line as it may lead to rupture or other hazards or failures.
3. Make sure no refrigerant gas is leaking when installation is completed.
4. If there is refrigerant leakage, please take sufficient measure to minimize the density of refrigerant.
5. Never touch the refrigerant piping or compressor without wearing gloves to avoid scald or frostbite.

Improper installation may lead to fire hazard, explosion, electric shock or injury.

Safety Precautions for Installing and Relocating the Unit:

To ensure safety, please be mindful of the following precautions.



Warnings

- 1. When installing or relocating the unit, be sure to keep the refrigerant circuit free from air or substances other than the specified refrigerant.**
Any presence of air or other foreign substance in the refrigerant circuit will cause system pressure rise or compressor rupture, resulting in injury or system failure.
- 2. When installing or moving this unit, do not charge with any refrigerant which does not comply with that on the nameplate.**
Otherwise, it may cause abnormal operation, mechanical malfunction or even serious safety hazard.
- 3. When refrigerant needs to be recovered during relocating or repairing the unit, be sure that the unit is running in cooling mode. Then, fully close the valve at high pressure side (liquid valve). About 30-40 seconds later, fully close the valve at low pressure side (gas valve), immediately stop the unit and disconnect power. Please note that the time for refrigerant recovery should not exceed one (1) minute.**
If refrigerant recovery takes too much time, air may be sucked in and cause pressure rise or compressor rupture, resulting in injury.
- 4. After refrigerant recovery, make sure that liquid valve and gas valve are fully closed and power is disconnected before detaching the connection pipe.**
If compressor starts running when stop valve is open and connection pipe is not yet connected, air will be sucked in and cause pressure rise or compressor rupture, resulting in injury.
- 5. When installing the unit, make sure that connection pipe is securely connected before the compressor starts running.**
If compressor starts running when stop valve is open and connection pipe is not yet connected, air will be sucked in and cause pressure rise or compressor rupture, resulting in injury.
- 6. Prohibit installing the unit where there may be corrosive or flammable gas.**
If there is leaked gas around the unit, it may cause explosion or other accidents.
- 7. Use the specified types of wires for electrical connections between the indoor and outdoor units. Firmly clamp the wires so that their terminals receive no external stresses.**
Electric wires with insufficient capacity, wrong wire connections and insecure wire terminals may cause electric shock or fire.

8. Installation

8.1 Installation Dimension Diagram

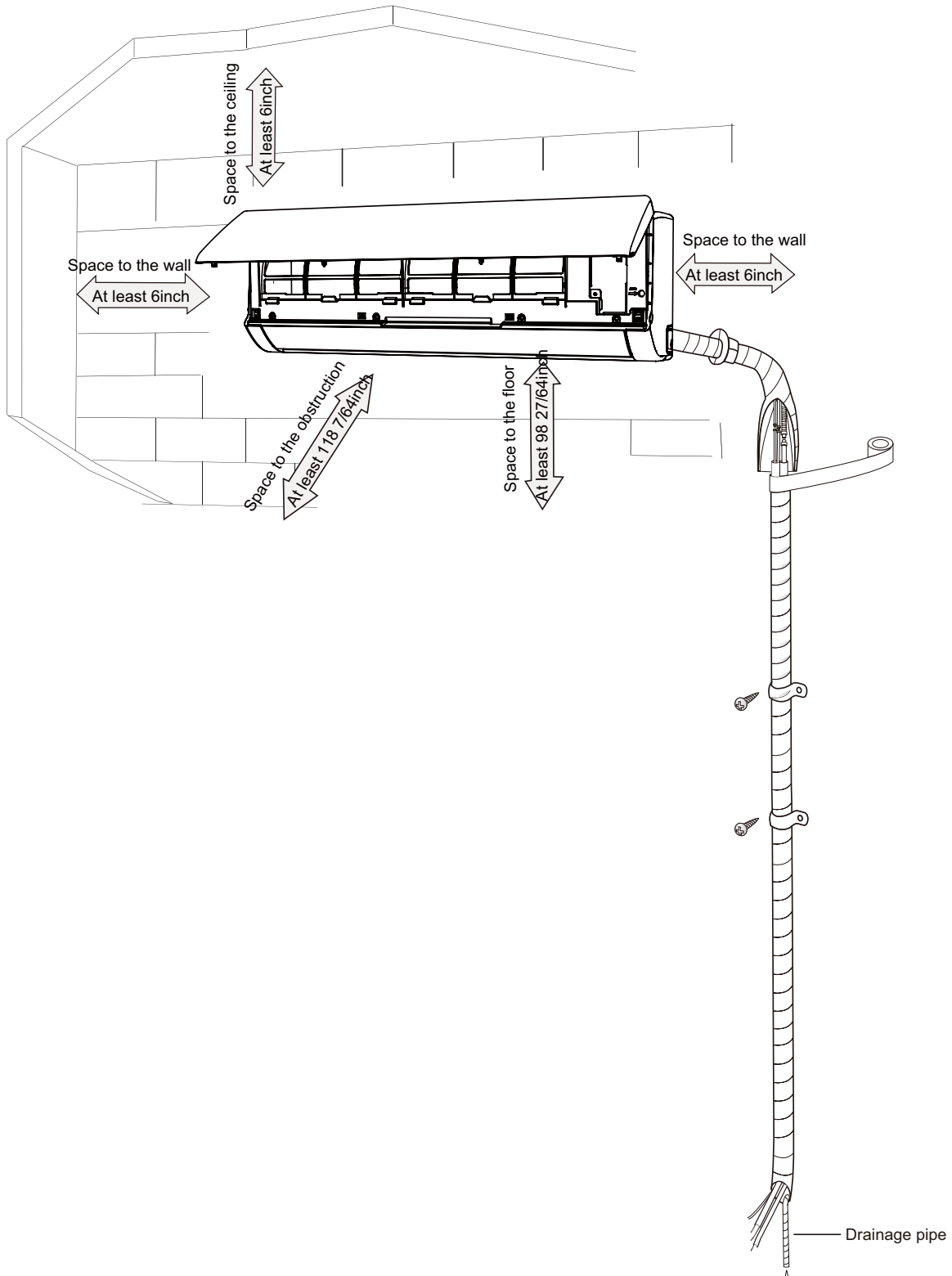

Installation procedures

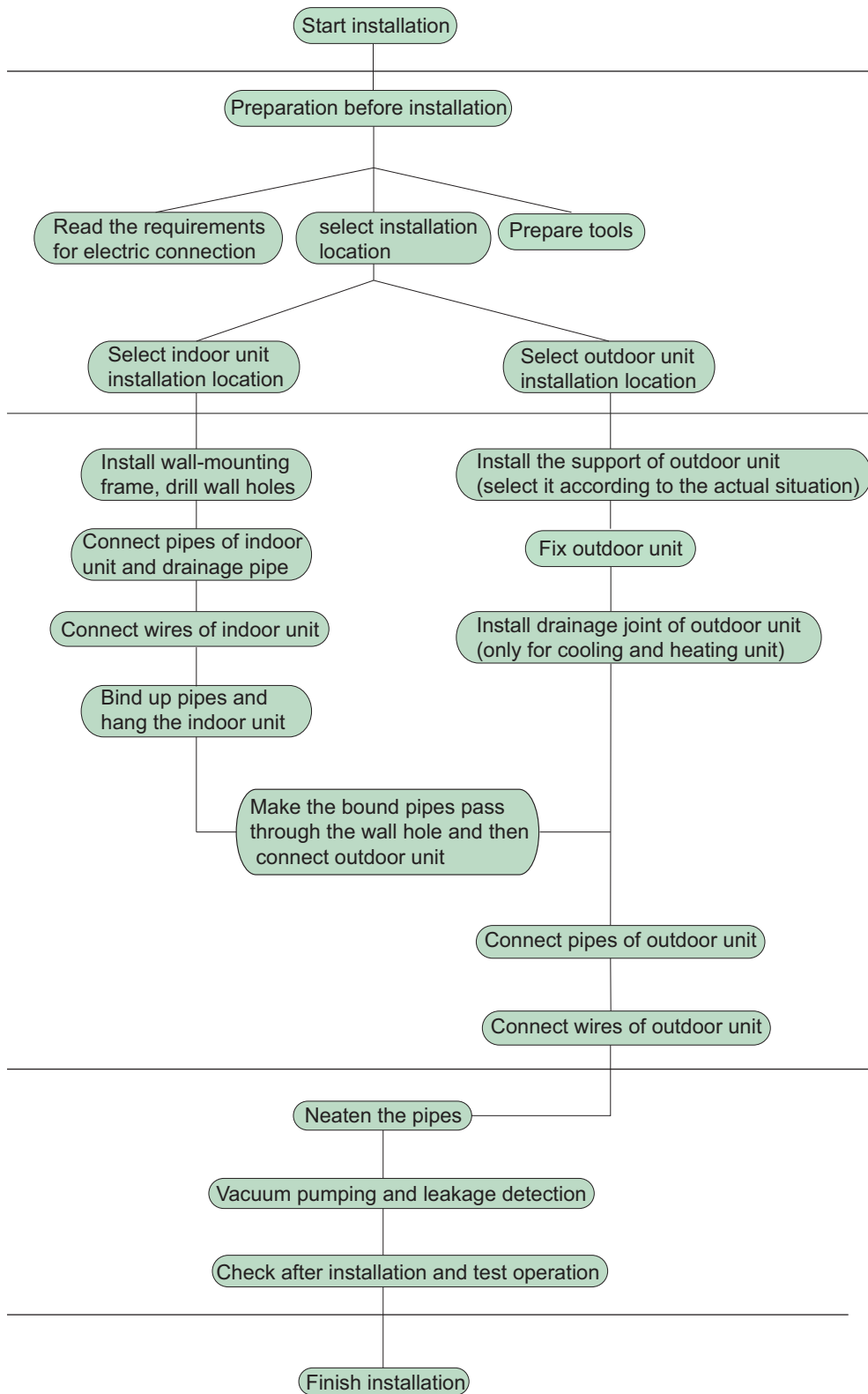

Note: this flow is only for reference; please find the more detailed installation steps in this section.

8.2 Installation Parts-checking

No.	Name	No.	Name
1	Indoor unit	8	Sealing gum
2	Outdoor unit	9	Wrapping tape
3	Connection pipe	10	Support of outdoor unit
4	Drainage pipe	11	Fixing screw
5	Wall-mounting frame	12	Drainage plug(cooling and heating unit)
6	Connecting cable(power cord)	13	Owner's manual, remote controller
7	Wall pipe		

⚠ Note:

1. Please contact the local agent for installation.
2. Don't use unqualified power cord.

8.3 Selection of Installation Location

1. Basic Requirement:

Installing the unit in the following places may cause malfunction. If it is unavoidable, please consult the local dealer:

- (1) Areas with strong heat sources, vapors, flammable or explosive gas, or volatile objects spread in the air.
- (2) Places with high-frequency devices (such as welding machine, medical equipment).
- (3) Places near coast area.
- (4) Places with oil or fumes in the air.
- (5) Places with sulfureted gas.
- (6) Other places with special circumstances.
- (7) Do not use the unit in the immediate surroundings of a laundry, bath, shower, or swimming pool.

2. Indoor Unit:

- (1) There should be no obstruction near air inlet and air outlet.
- (2) Select a location where the condensation water can be dispersed easily and won't affect other people.
- (3) Select a location which is convenient to connect the outdoor unit and near the power socket.
- (4) Select a location which is out of reach for children.
- (5) The location should be able to withstand the weight of indoor unit and not increase noise and vibration.
- (6) The appliance must be installed 6.5 ft. above floor.
- (7) Don't install the indoor unit right above any electric appliance.
- (8) Please try your best to keep way from fluorescent lamps.

8.4 Electric Connection Requirement

1. Safety Precaution

- (1) You must follow the electric safety regulations when installing the unit.
- (2) According to the local safety regulations, use qualified power supply circuit and disconnect.

- (3) Make sure the power supply matches with the requirement of the air conditioner. Unstable power supply or incorrect wiring may result in electric shock, fire hazard or malfunction. Please install proper power supply cables before using the air conditioner.
- (4) Properly connect the live wire, neutral wire and grounding wire of power socket.
- (5) Be sure to cut off the power supply before proceeding with any work related to electricity and safety.
- (6) Do not turn on the power before finishing installation.
- (7) If the supply cord is damaged, it must be replaced by the service agent or similarly qualified persons in order to avoid a hazard.
- (8) The temperature of refrigerant circuit will be high, please keep the interconnection cable away from the copper tube.
- (9) The appliance shall be installed in accordance with national wiring regulations.

2. Grounding Requirement:

- (1) The air conditioner is first class electric appliance. It must be properly grounded with specialized grounding device by a professional. Please make sure it is always grounded effectively, otherwise it may cause electric shock.
- (2) The yellow-green wire in air conditioner is grounding wire, which can't be used for other purposes.
- (3) The grounding resistance should comply with national electric safety regulations.
- (4) The appliance must be positioned so that the plug is accessible.
- (5) An all-pole disconnection switch having a contact separation of at least .12" in all poles should be connected in fixed wiring.
- (6) Including an air switch with suitable capacity, please note the following table. Airswitch should be included magnet buckle and heating buckle function, it can protect the circuit-short and overload. (Caution: Please do not use the fuse only for protect the circuit)

8.5 Installation of Indoor Unit

1. Choosing Installation Location

Recommend the installation location to the client and then confirm it with the client.

2. Install Wall-mounting Frame

- (1) Hang the wall-mounting frame on the wall; adjust it in horizontal position with a level and then mark the screw fixing holes on the wall.
- (2) Drill the screw mounting holes on the wall with impact drill (the specification of drill head should be the same as the plastic insert). Then place the plastic inserts in the holes.
- (3) Fix the wall-mounting frame on the wall with tapping screws (ST4.2X25TA) and then check if the frame is firmly installed by pulling the frame. If the plastic insert is loose, please drill another mounting hole nearby.

3. Install Wall-mounting Frame

- (1) Choose the position of piping hole according to the direction of outlet pipe. The position of piping hole should be a little lower than the wall-mounted frame. (As shown in Fig. 1)

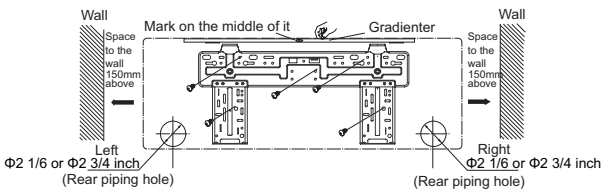

Fig.1

- (2) Open a piping hole with the diameter of $\Phi 2 \frac{1}{6}$ or $\Phi 2 \frac{3}{4}$ inch on the selected outlet pipe position. In order to drain smoothly, slant the piping hole on the wall slightly downward to the outdoor side with the gradient of $5-10^\circ$. (As shown in Fig. 2)

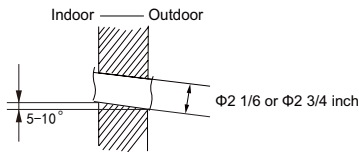

Fig.2

⚠ Note:

- (1) Pay attention to dust prevention and take relevant safety measures when opening the hole.
- (2) Wall anchors are not provided and should be bought locally.

4. Outlet Pipe

- (1) The pipe can be led out in the direction of right, rear right, left or rear left. (As shown in Fig. 3)
- (2) When selecting leading out the pipe from left or right, please cut off the corresponding hole on the bottom case. (As shown in Fig. 4)

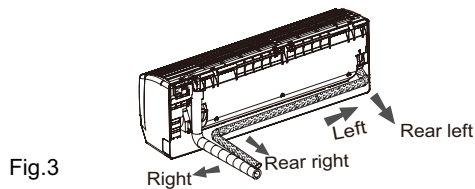

Fig.3

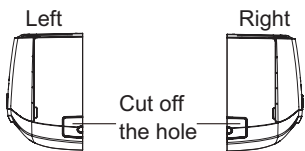

Fig.4

5. Connect the Pipe of Indoor Unit

- (1) Aim the pipe joint at the corresponding bellmouth. (As shown in Fig. 5)
- (2) Pretighten the union nut with hand.
- (3) Adjust the torque force by referring to the following sheet. Place the open-end wrench on the pipe joint and place the torque wrench on the union nut. Tighten the union nut with torque wrench. (As shown in Fig. 6)
- (4) Wrap the indoor pipe and joint of connection pipe with insulating pipe, and then wrap it with tape. (As shown in Fig. 7)
- (5) If a 18k indoor unit is to be connected with outdoor unit, a transitional pipe joint (provided) should be added at the pipe joint of indoor unit evaporator assy as the pipe joint of evaporator assy adopts pipe diameter of $\Phi 5/8$. Please refer to step 1~4 during installation.

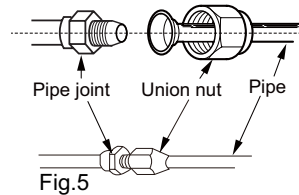

Fig.5

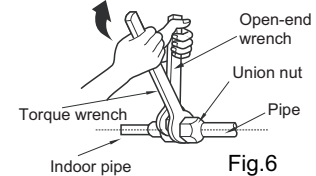

Fig.6

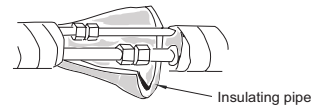

Fig.7

Refer to the following table for wrench moment of force:

Hex nut diameter(inch)	Tightening torque(ft-lbf)
$\Phi 1/4$	11.10~14.75
$\Phi 3/8$	20.12~29.50
$\Phi 1/2$	33.19~40.56
$\Phi 5/8$	44.24~47.94
$\Phi 3/4$	51.32~55.31

6. Install Drain Hose

- (1) Connect the drain hose to the outlet pipe of indoor unit. (As shown in Fig. 8)
- (2) Bind the joint with tape. (As shown in Fig. 9)

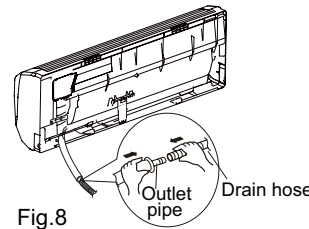

Fig.8

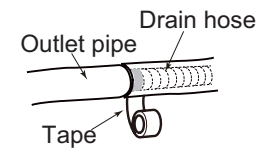

Fig.9

⚠ Note:

- (1) Add insulating pipe in the indoor drain hose in order to prevent condensation.
- (2) The plastic expansion particles are not provided. (As shown in Fig. 10)

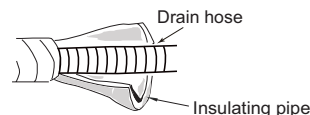
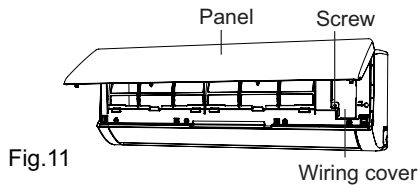

Fig.10

7. Connect Wire of Indoor Unit

- (1) Open the panel, remove the screw on the wiring cover and then take down the cover. (As shown in Fig. 11)



- (2) Make the power connection wire go through the cable-cross hole at the back of indoor unit and then pull it out from the front side. (As shown in Fig. 12)

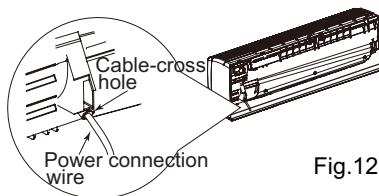

- (3) Remove the wire clip; connect the power connection wire to the wiring terminal according to the color; tighten the screw and then fix the power connection wire with wire clip. (As shown in Fig. 13)

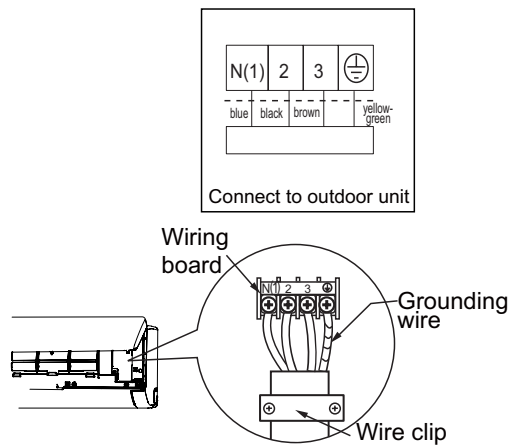

Note: The wiring connection is for reference only.

Fig.13

- (4) Put wiring cover back and then tighten the screw.
- (5) Close the panel.

⚠ Note:

- (1) All wires of indoor unit and outdoor unit should be connected by a professional.
- (2) A circuit breaker must be installed in the line. The circuit breaker should be all-pole parting and the contact parting distance should be more than 3mm.

8. Bind up Pipe

- (1) Bind the connection pipe, power cord and drain hose with the band. (As shown in Fig. 14)
- (2) Reserve a certain length of drain hose and power cord for installation when binding them. When binding separate the indoor power and then separate the drain hose. (As shown in Fig. 15)
- (3) Bind them evenly.
- (4) The liquid pipe and gas pipe should be bound separately at the end.

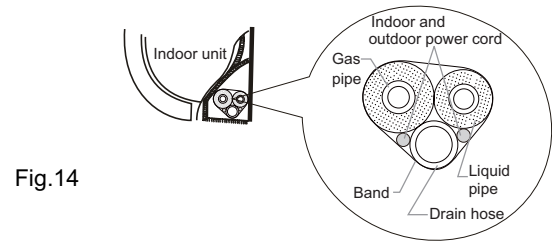

Fig.14

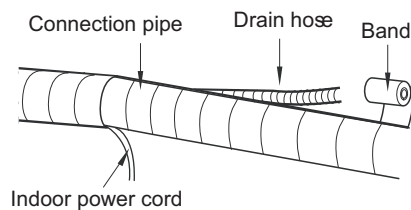

Fig.15

⚠ Note:

- (1) The power cord and control wire can't be crossed or winding.
- (2) The drain hose should be bound on the bottom.

9. Hang the Indoor Unit

- (1) Put the bound pipes in the wall pipe, then pass through the wall hole.
- (2) Hang the indoor unit on the wall-mounting frame.
- (3) Stuff the gap between pipes and wall hole with sealing gum.
- (4) Fix the wall pipe. (As shown in Fig. 16)
- (5) Check if the indoor unit is installed firmly and tight to the wall. (As shown in Fig. 17)

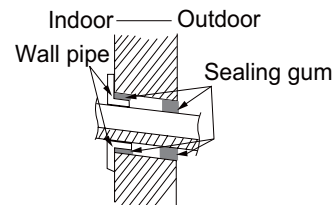
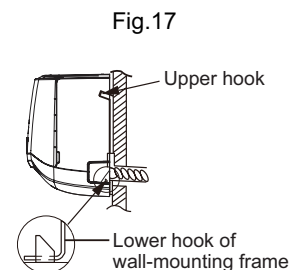

Fig.16



⚠ Note:

Do not bend the drain hose too excessively in order to prevent blocking.

8.6 Check after Installation and Test Operation

1. Check after Installation

Check according to the following requirement after finishing installation.

No.	Items to be checked	Possible malfunction
1	Has the unit been installed securely?	The unit may drop, shake or emit noise.
2	Have you performed a refrigerant leakage test?	It may cause insufficient cooling (heating) capacity.
3	Is heat insulation of pipe refrigerant sufficient?	It may cause condensation, water dripping, loss of capacity.
4	Is water draining well?	It may cause condensation and water dripping.
5	Does the voltage of power supply match the voltage marked on the nameplate?	It may cause failure, or damage the parts.
6	Is electric wiring and refrigerant pipe installed correctly?	It may cause failure, or damage the parts.
7	Is the unit grounded securely?	It may cause electric leakage.
8	Does the power cord follow the specification?	It may cause failure, or damage the parts.
9	Is there any obstruction in air inlet and air outlet?	It may cause insufficient cooling (heating) capacity.
10	Has the dust and debris caused during installation been removed?	It may cause failure, or damage the parts.
11	Are the gas valve and liquid valve of connection pipe open completely?	It may cause insufficient cooling (heating) capacity.
12	Have the inlet and outlet of wall penetration been covered?	It may cause insufficient cooling (heating) capacity or waste electricity.

2. Test Operation

(1) Preparation of test operation

- The client approves the air conditioner installation.
- Specify the important notes for air conditioner to the client.

(2) Method of test operation

- Put through the power, press ON/OFF button on the remote controller to start operation.
- Press MODE button to select AUTO, COOL, DRY, FAN and HEAT to check whether the operation is normal.
- If the ambient temperature is lower than 61°F(16°C), the air conditioner can't start cooling.

9. Maintenance

9.1 Error Code

1. Requirement of malfunction display

When several malfunctions happen at the same time, malfunction codes will be displayed circularly.

2. Malfunction display method

- (1) Hardware malfunction: it will be displayed immediately, please refer to “Malfunction status sheet”;
- (2) Operation status: it will be displayed immediately, please refer to “Malfunction status sheet”;
- (3) Other malfunction: It will be displayed after the compressor has been stopped for 200s, please refer to “Malfunction status sheet”.

(Note: when the compressor starts up again, malfunction display waiting time (200s) will be cleared.)

3. Malfunction display control

Indoor unit displays malfunction code as shown in the sheet below. ODU communication light will be off for 1s and then blink for 1s circularly.

4. Viewing malfunction code through remote controller

Enter viewing malfunction code: pressing light button for 4 times within 3S to view malfunction code;

Exit viewing malfunction code: pressing light button for 4 times within 3S or after the malfunction code is displayed for 5min.

Malfunction name	Malfunction type	Nixie tube
Malfunction protection of jumper cap	Hardware malfunction	C5
Feedback of without IDU motor	Hardware malfunction	H6
Indoor ambient temperature sensor is open/short circuited	Hardware malfunction	F1
Indoor evaporator temperature sensor is open/short circuited	Hardware malfunction	F2
Liquid valve temperature sensor is open/short circuited	Hardware malfunction	b5
Gas valve temperature sensor is open/short circuited	Hardware malfunction	b7
Modular temperature sensor is open/short circuited	Hardware malfunction	P7
Outdoor ambient temperature sensor is open/short circuited	Hardware malfunction	F3
Outdoor condenser inlet pipe temperature sensor is open/short circuited (commercial)	Hardware malfunction	A5
Outdoor condenser middle pipe temperature sensor is open/short circuited	Hardware malfunction	F4
Outdoor condenser outlet pipe temperature sensor is open/short circuited (commercial)	Hardware malfunction	A7
Outdoor discharge temperature sensor is open/short circuited	Hardware malfunction	F5
Communication malfunction	Hardware malfunction	E6
Malfunction of phase current detection circuit for compressor	Hardware malfunction	U1
Compressor demagnetization protection	Viewing malfunction code through remote controller within 200s; displayed directly on nixietube after 200s	HE
Malfunction of voltage dropping for DC bus-bar		U3
Module high temperature protection		P8
Refrigerant low or blockage protection of system (not available for residential ODU)		F0
Charging malfunction of capacitor	Hardware malfunction	PU
High pressure protection of system	Hardware malfunction	E1
Low pressure protection of system (reserved)	Hardware malfunction	E3

Compressor overload protection	Viewing malfunction code through remote controller within 200s; displayed directly on nixietube after 200s	H3
Indoor unit and outdoor unit do not match	Hardware malfunction	LP
Malfunction of memory chip	Hardware malfunction	EE
Malfunction of complete units current detection	Hardware malfunction	U5
Malfunction protection of outdoor fan 1	Hardware malfunction	L3
Mode conflict	Operation status	E7
Refrigerant recycling mode	Operation status	Fo
X-fan	Operation status	Heating mode indicator is on for 10s and then off for 0.5s
Defrosting or oil return in heating mode	Operation status	Cooling mode indicator is on for 0.5s and then off for 10s
Start failure of compressor	Viewing malfunction code through remote controller within 200s; displayed directly on nixietube after 200s	Lc
High discharge temperature protection of compressor		E4
Overload protection		E8
Whole unit overcurrent protection		E5
Compressor phase current protection		P5
Compressor desynchronizing		H7
Compressor phase-lacking/phase-inverse protection		Ld
IPM modular protection		H5
DC bus-bar low voltage protection		PL
DC bus-bar high voltage protection		PH
PFC protection		HC
The four-way valve is abnormal		U7

9.2 Procedure of Troubleshooting

1. Malfunction of Temperature Sensor F1, F2

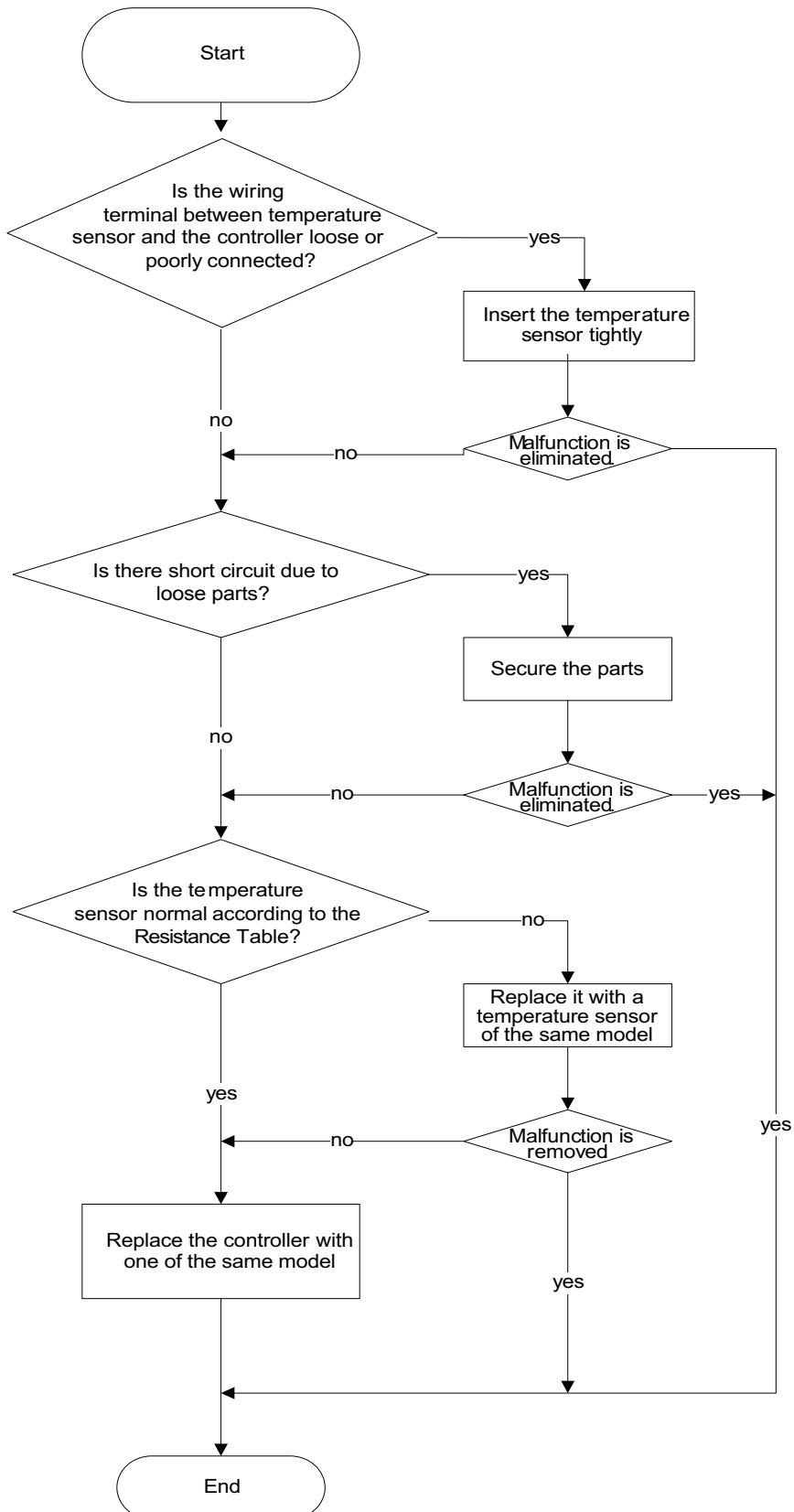

2. Malfunction of Blocked Protection of IDU Fan Motor H6

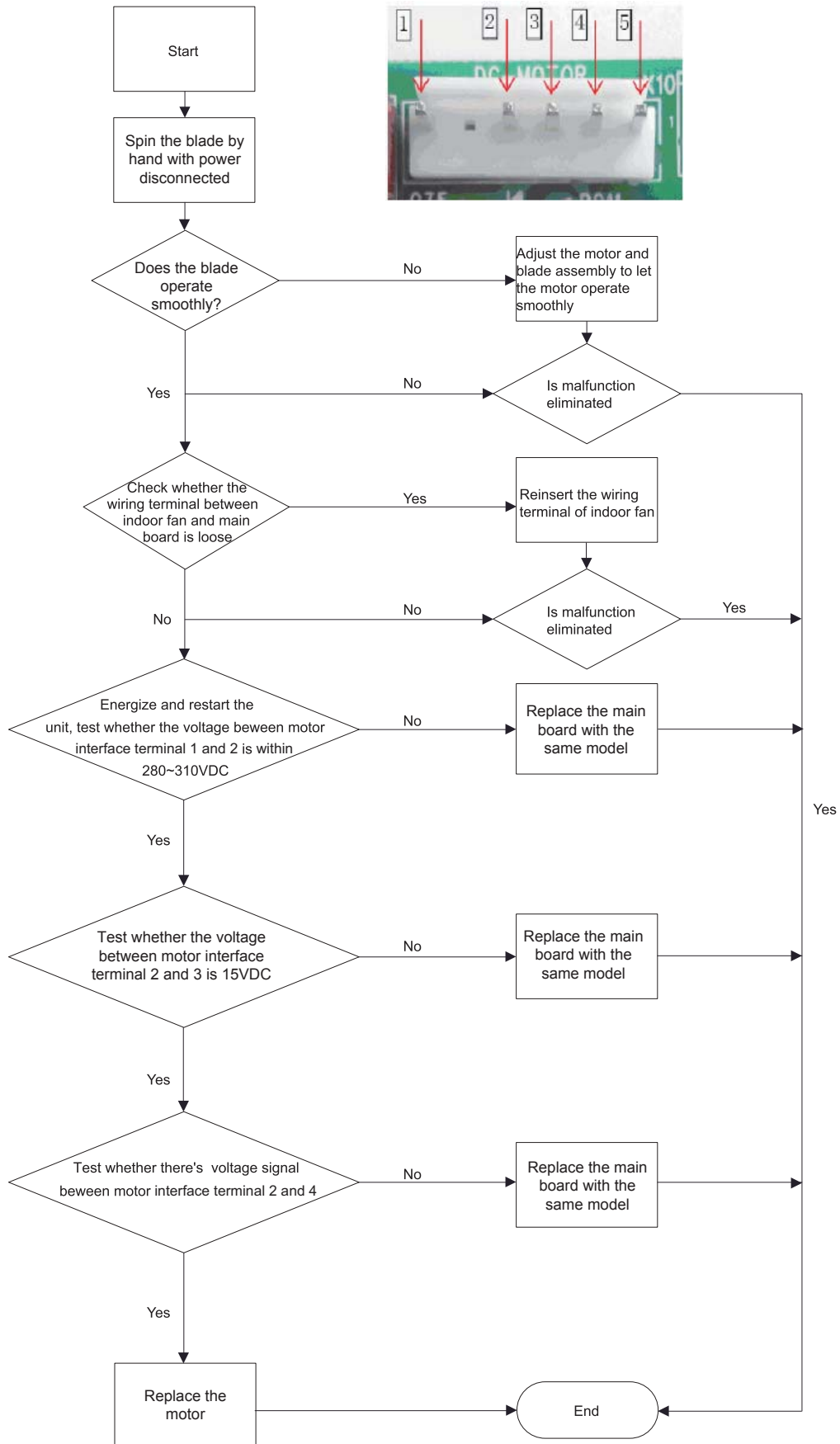

3. Malfunction of Protection of Jumper Cap C5

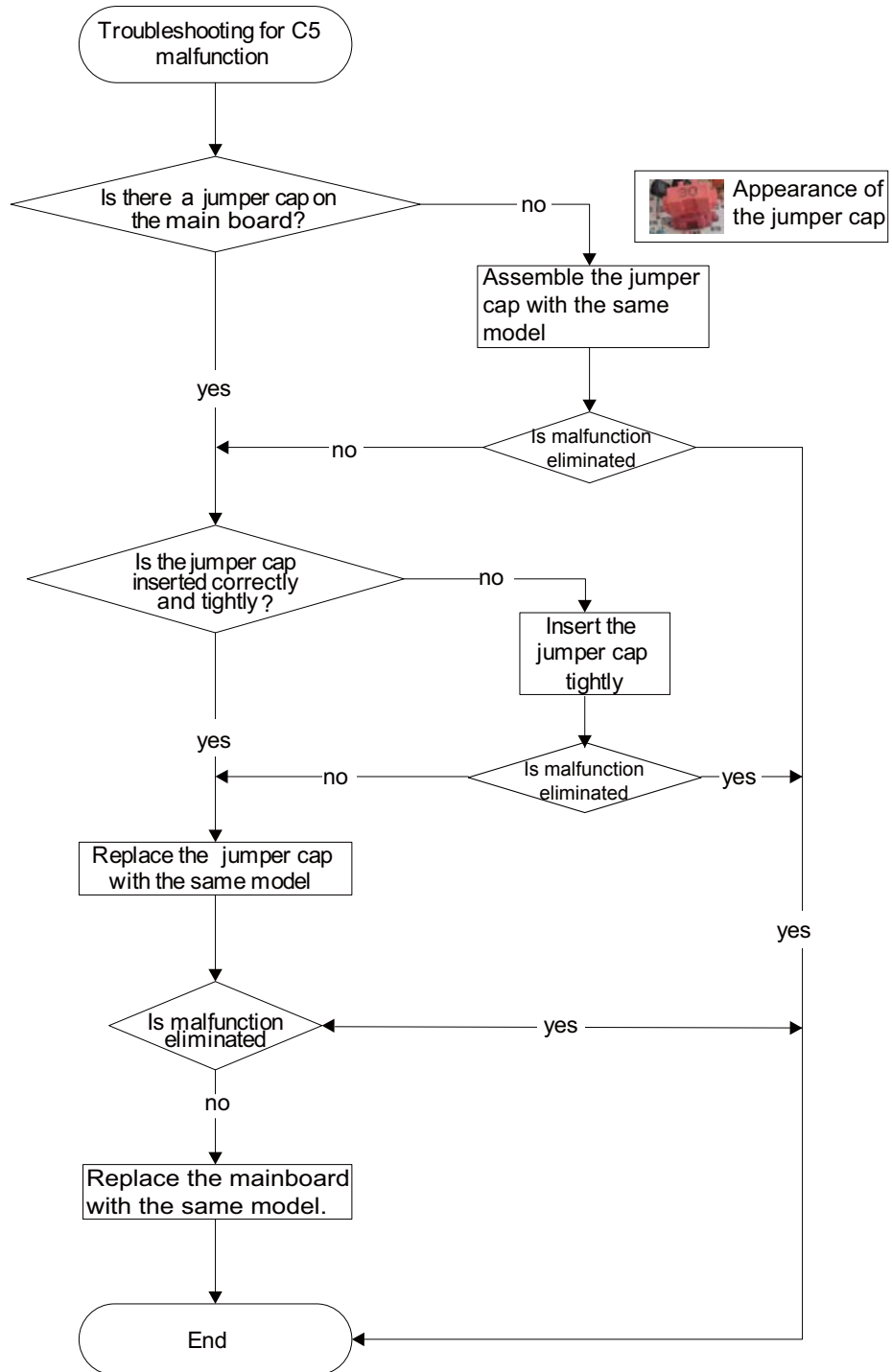

4. E6 Malfunction

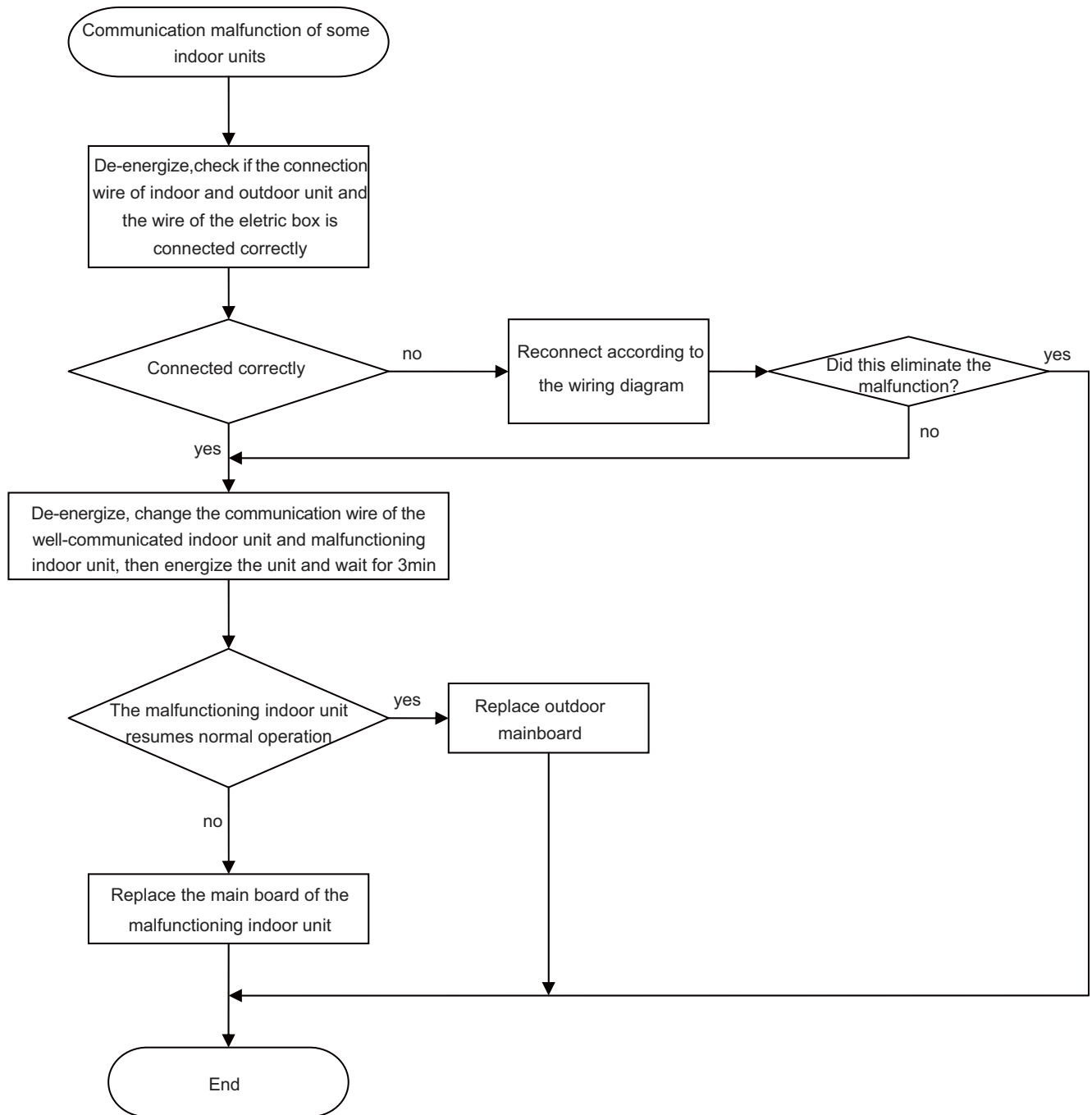

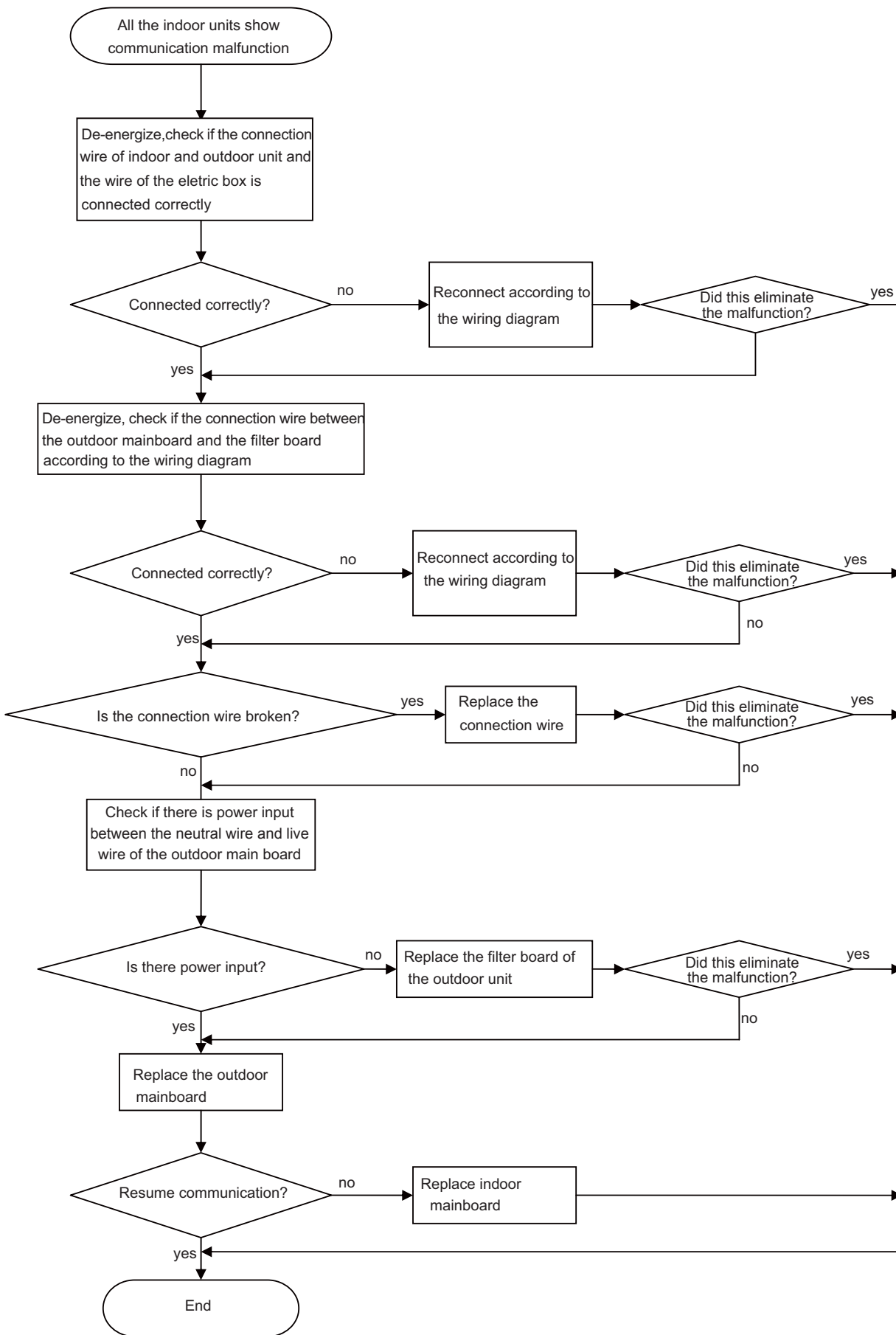

10. Exploded View and Parts Lists

Exploded View

Model B-VFH09MB-1

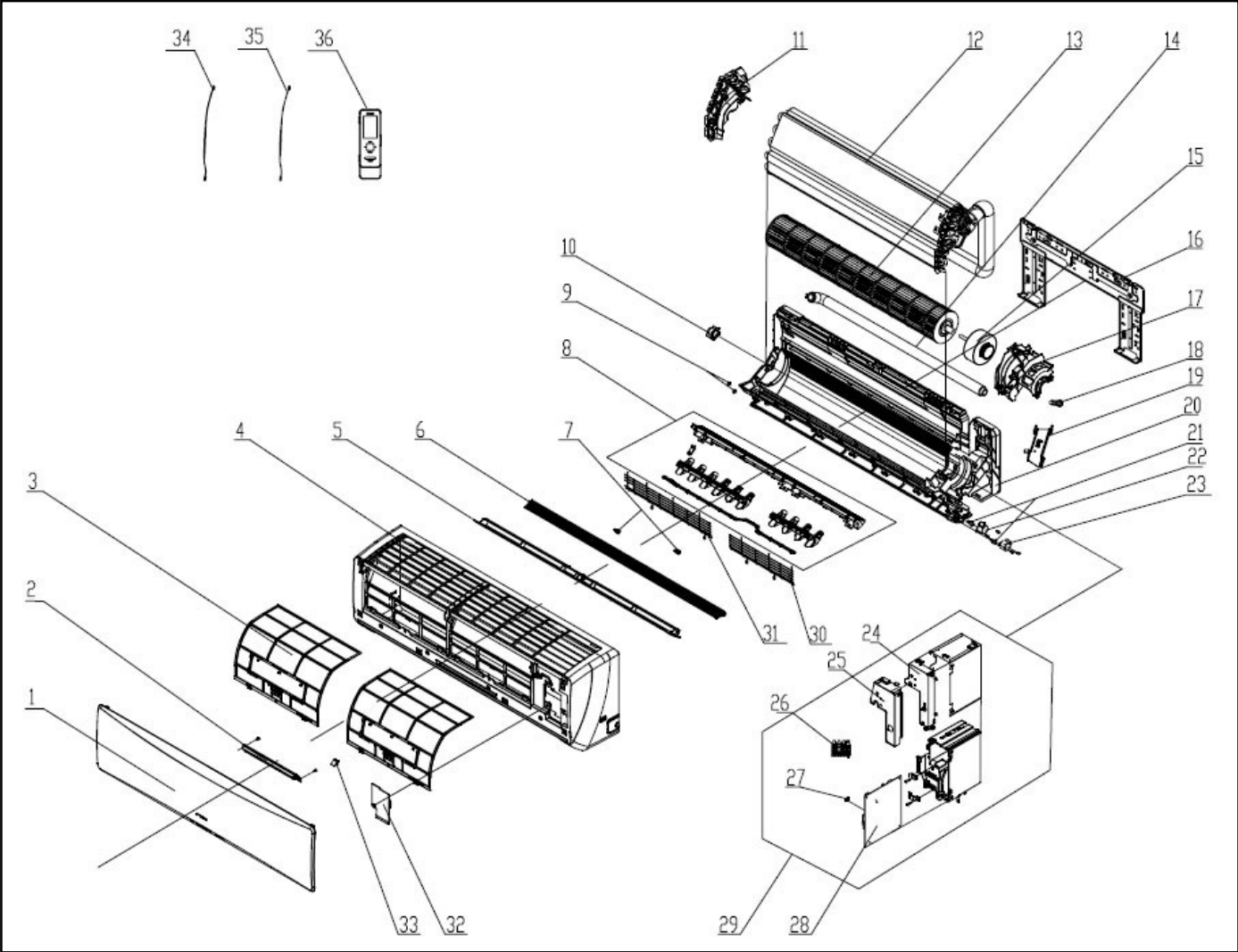

Replacement Parts

Model B-VFH09MB-1

Location	Part Name	Quantity	Part No.
1	Front Panel	1	27230007938
2	Display Board	1	30565140
3	Filter Sub-Assembly	2	1112211602
4	Front Case Sub-Assembly	1	2001288902
5	Guide Louver	1	10512267
6	Guide Louver (small)	1	10512127
7	Crank	2	10582070
8	Helicoid Tongue Sub-Assembly	1	2611224404
9	Left Axle Bushing	2	10512037
10	Propeller Axle Bushing	1	1054202101
11	Evaporator Support	1	24212114
12	Evaporator Assembly	1	01002641_L61437
13	Cross Flow Fan	1	10352033
14	Drainage Hose	1	05230014
15	Fan Motor	1	15012510
16	Wall Mounting Frame	1	01252484
17	Motor Press Plate	1	26112209
18	Rubber Plug (Water Tray)	1	76712012
19	Connecting Pipe Clamp	1	2611216402
20	Rear Case Assembly	1	2220216103
21	Axle Bushing	3	10542036
22	Stepping Motor	1	15212126
23	Stepping Motor	1	15212125
24	Shield Cover of Electric Box	1	01592084
25	Electric Box Cover	1	2012240903
26	Terminal Board	1	42011233
27	Jumper	1	4202300107
28	Main Board	1	30138000315
29	Electric Box Assembly	1	10000200568
30	Rear Grill	1	01472030
31	Rear Grill	1	01472029
32	Electric Box Cover 2	1	2012207504
33	Screw Cover	1	24252016
34	Temperature Sensor	1	390000451
35	Temperature Sensor	1	390000598
36	Remote Controller	1	30510138_L61437

Exploded View

Model B-VFH12MB-1

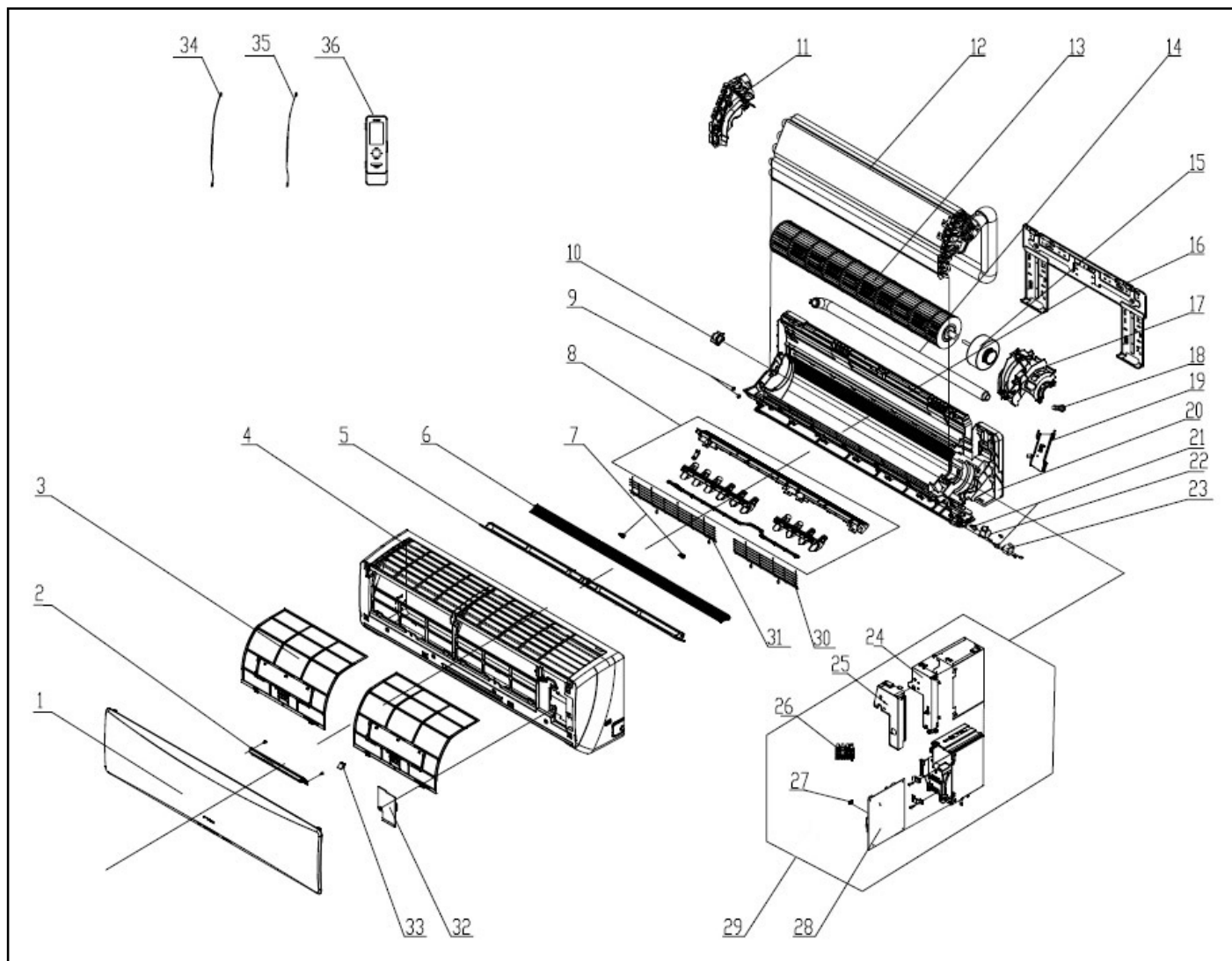

Replacement Parts

Model B-VFH12MB-1

Location	Part Name	Quantity	Part No.
1	Front Panel	1	27230007938
2	Display Board	1	30565140
3	Filter Sub-Assembly	2	1112211602
4	Front Case Sub-Assembly	1	2001288902
5	Guide Louver	1	10512267
6	Guide Louver (Small)	1	10512127
7	Crank	2	10582070
8	Helicoid Tongue Sub-Assembly	1	2611224404
9	Left Axle Bushing	2	10512037
10	Propeller Axle Bushing	1	1054202101
11	Evaporator Support	1	24212114
12	Evaporator Assembly	1	01002641_L61437
13	Cross Flow Fan	1	10352033
14	Drainage Hose	1	05230014
15	Fan Motor	1	15012510
16	Wall Mounting Frame	1	01252484
17	Motor Press Plate	1	26112209
18	Rubber Plug (Water Tray)	1	76712012
19	Connecting Pipe Clamp	1	2611216402
20	Rear Case Assembly	1	2220216103
21	Axle Bushing	3	10542036
22	Stepping Motor	1	15212126
23	Stepping Motor	1	15212125
24	Shield Cover of Electric Box	1	01592084
25	Electric Box Cover	1	2012240903
26	Terminal Board	1	42011233
27	Jumper	1	4202300108
28	Main Board	1	30138000315
29	Electric Box Assembly	1	10000200569
30	Rear Grill	1	01472030
31	Rear Grill	1	01472029
32	Electric Box Cover 2	1	2012207504
33	Screw Cover	1	24252016
34	Temperature Sensor	1	390000451
35	Temperature Sensor	1	390000598
36	Remote Controller	1	30510138_L61437

Exploded View

Model B-VFH18MC-1

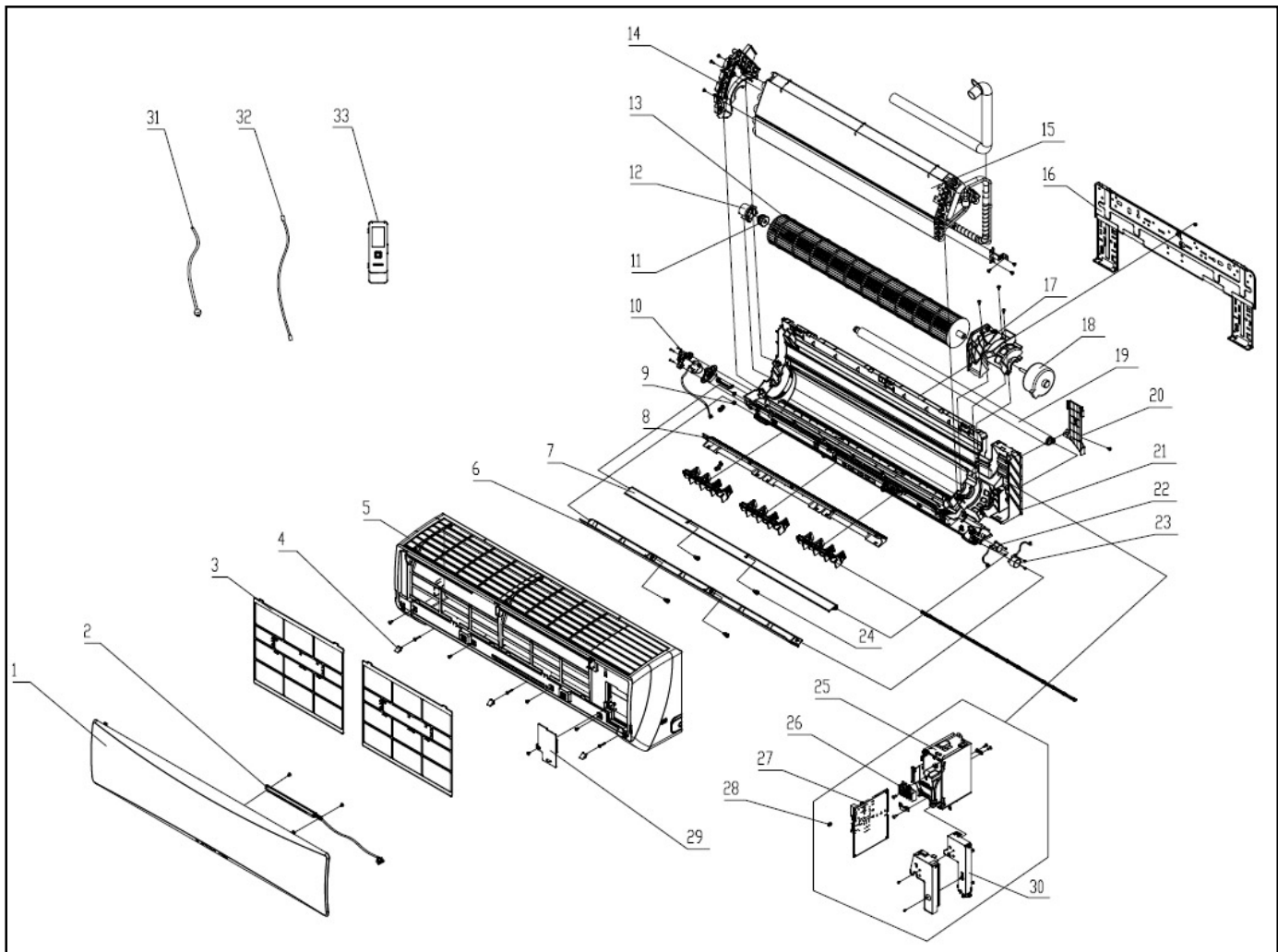

Replacement Parts

Model B-VFH18MC-1

Location	Part Name	Quantity	Part No.
1	Front Panel	1	27230007939
2	Display Board	1	30565141
3	Filter Sub-Assembly	2	1112209105
4	Screw Cover	3	24252016
5	Front Case	1	20012821
6	Guide Louver	1	10512283
7	Guide Louver (Small)	1	1051222601
8	Helicoid Tongue	1	2611236701
9	Left Axle Bushing	2	1051203701
10	Stepping Motor	1	1501208602
11	O-Gasket of Cross Fan Bearing	1	76512203
12	Ring of Bearing	1	26152025
13	Cross Flow Fan	1	10352045
14	Evaporator Support	1	24212139
15	Evaporator Assembly	1	0100238601_L61437
16	Wall Mounting Frame	1	01252123
17	Motor Press Plate	1	26112330
18	Fan Motor	1	1501212701
19	Drainage Hose	1	0523001406
20	Connecting Pipe Clamp	1	26112188
21	Rear Case Assembly	1	22202499
22	Stepping Motor	1	15212404
23	Stepping Motor	1	1521212901
24	Axle Bushing	4	10542036
25	Electric Box	1	2011218104
26	Terminal Board	1	42011233
27	Main Board	1	30138000312
28	Jumper	1	4202300115
29	Electric Box Cover 2	1	2012214209
30	Electric Box Cover	1	2012240903
33	Remote Controller	1	30510138_L61437

Exploded View

Model B-VFH24MB-1

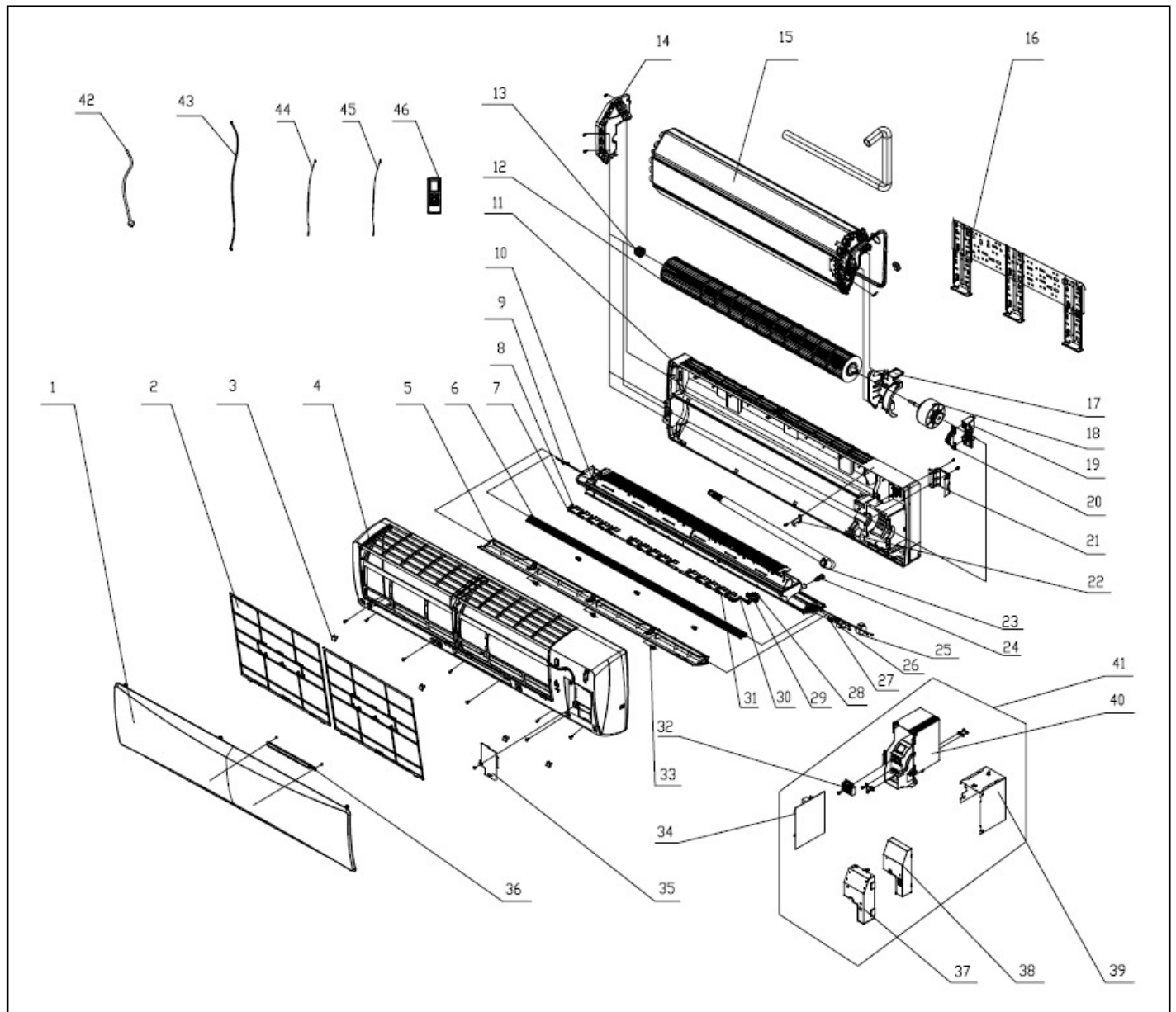

Replacement Parts

Model B-VFH24MB-1

Location	Part Name	Quantity	Part No.
1	Front Panel	1	27230007940
2	Filter Sub-Assembly	2	11122136
3	Screw Cover	4	242520053
4	Front Case Sub-Assembly	1	20022004
5	Guide Louver	1	10512236
6	Small Guide Louver	1	1051223701
7	Swing Lever 2	1	1058211601
8	Air Louver	15	10512252
9	Left Axle Bushing	2	1051203701
10	Water Tray Assembly	1	01272119
11	Rear Case Sub-Assembly	1	22202092
12	Cross Flow Fan	1	10352420
13	O-Gasket of Cross Fan Bearing	1	76512203
14	Left Evaporator Support	1	24212041
15	Evaporator Assembly	1	01002000041_L61437
16	Wall Mounting Frame	1	01252398
17	Right Support of Evaporator	1	2421204201
18	Fan Motor	1	1501213401
19	Motor Fixed Clip 1	1	26112324
20	Motor Fixed Clip 2	1	26112325
21	Pipe Clamp	1	26112071
22	Fixed Clip (Evaporator)	1	02112009
23	Drainage Hose	1	0523001403
24	Rubber Plug (Water Tray)	1	76712012
25	Stepping Motor	1	1521212602
26	Stepping Motor	1	1521240208
27	Crank	2	73012021
28	Stepping Motor	1	1521212301
29	Motor Holder	1	26152046
30	Swing Lever 3	1	1058211701
31	Swing Lever 1	1	1058211501
32	Terminal Board	1	42011233
33	Axle Bushing	3	10542036
34	Main Board	1	30138000312
35	Electric Box Cover 2	1	2012214202
36	Display Board	1	30565141
37	Shield Cover of Electric Box Cover	1	01592108
38	Electric Box Cover	1	2012216401
39	Shield Cover of Electric Box	1	01592107
40	Electric Box	1	2011214001
41	Electric Box Assembly	1	20102000340
44	Temperature Sensor	1	390000451
45	Temperature Sensor	1	390000598
46	Remote Controller	1	30510138_L61437

11. Removal Procedure

 **Caution: discharge the refrigerant completely before removal.**

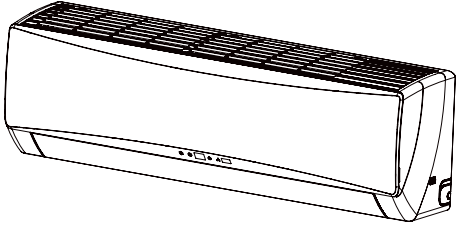
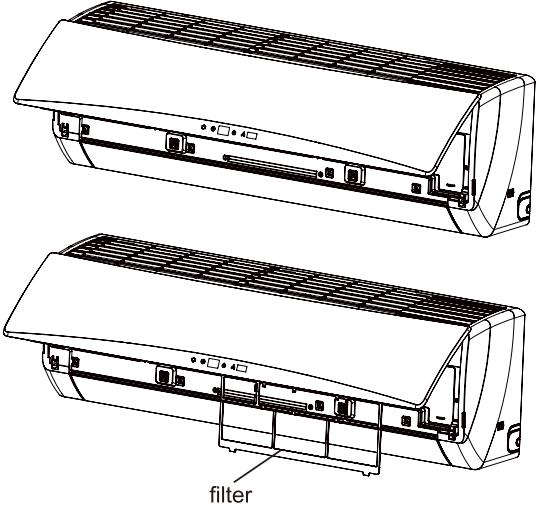
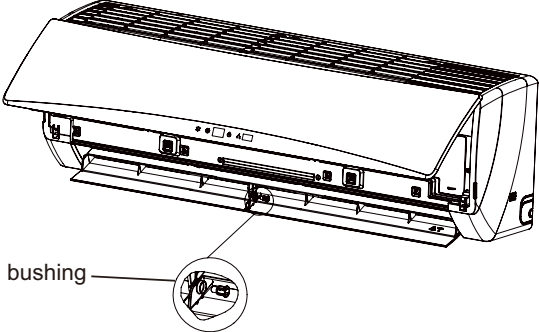
Steps		Procedure
1. Before disassembling the unit	Before disassembling the unit.	
2. Remove filter	<p>1 Open the panel.</p> <p>2 Loosen the clasps on filter, push the filter inward and then pull it upward, then the filter can be removed.</p>	
3. Remove guide louver	1 Remove the axial bushing of big guidelouver.	

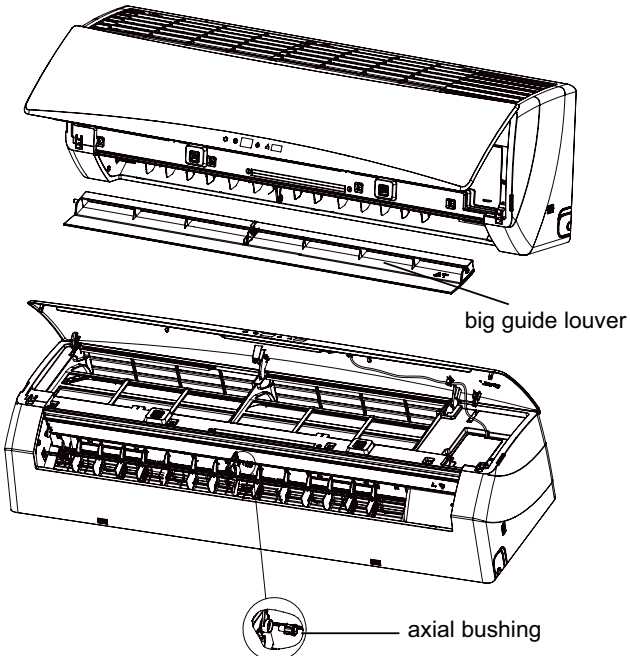
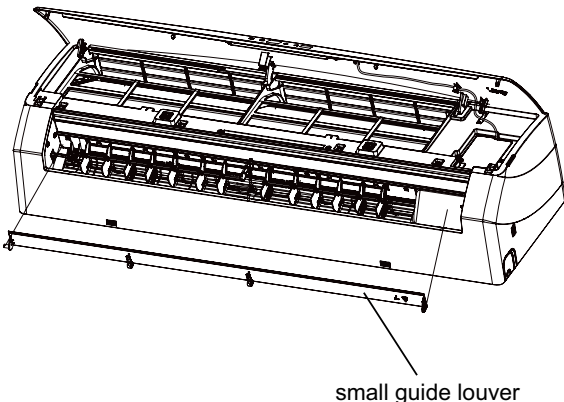
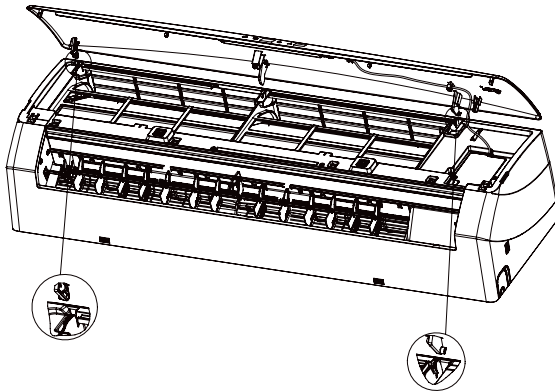
Steps	Procedure	
2	Remove the rotating shaft of big guide louver from the groove, slightly bend the big guide louver to remove it.	 <p>big guide louver</p> <p>axial bushing</p>
3	Remove the axial bushing of small guide louver.	 <p>small guide louver</p>
4. Remove panel		
1	Loosen the clamps of the panel to remove the panel.	

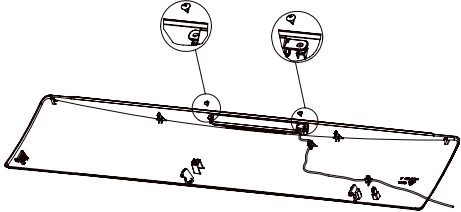
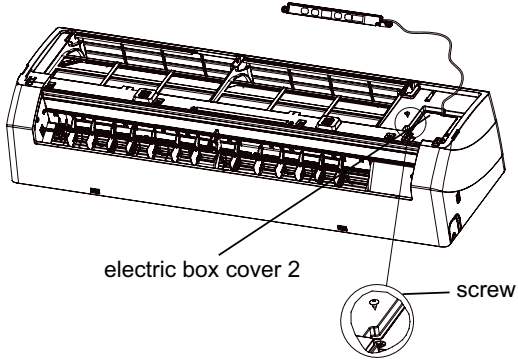
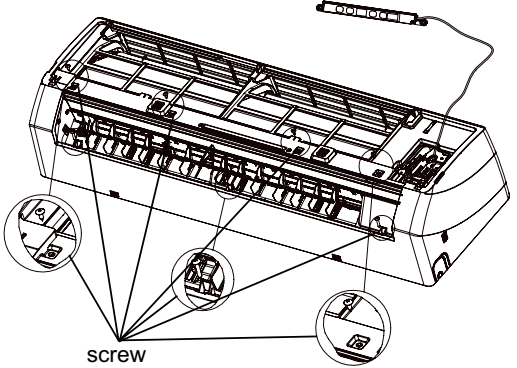
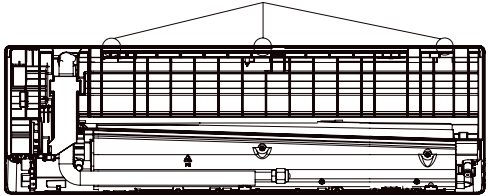
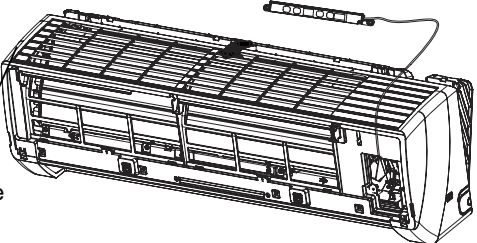
Steps	Procedure	
2	Remove the screws fixing display on the panel, to remove the display.	
5.Remove front case		
1	Remove the screws fixing electric box cover 2, to remove the electric box cover 2.	 <p>electric box cover 2</p> <p>screw</p>  <p>screw</p>
2	Remove the screws fixing front panel, loosen the clamps, to remove the front case.	 <p>clamp</p>  <p>front case</p>

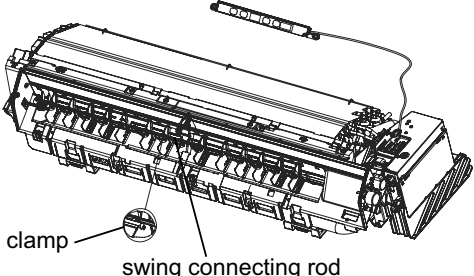
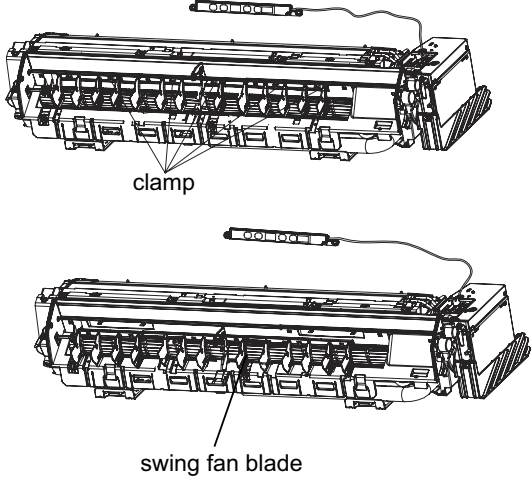
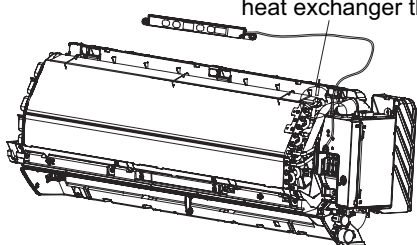
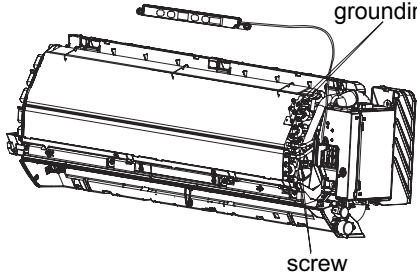
Steps	Procedure	
6.Remove swing fan blade		
1	Loosen the clamps fixing swing connecting rod, to remove the swing connecting rod.	
2	Remove the clamps fixing swing fan blade, to remove the swing fan blade.	
7.Remove electric box sub-assy		
1	Remove the indoor tube temp. sensor.	
2	Remove the screws fixing grounding wire, to remove the grounding wire.	

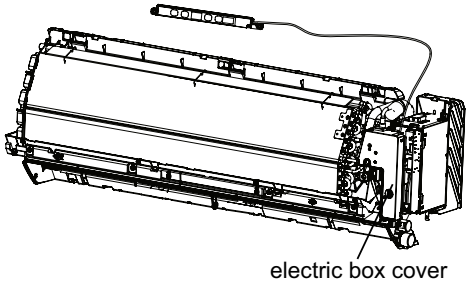
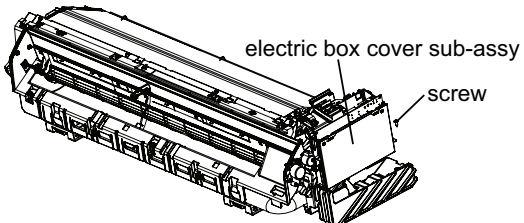
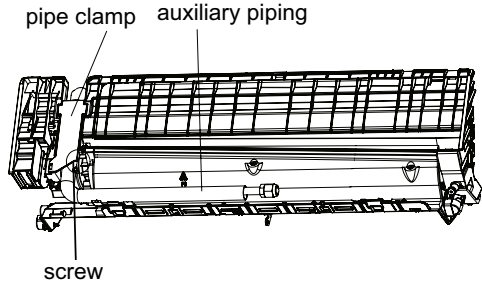
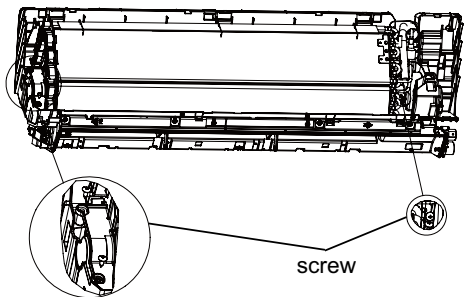
Steps	Procedure	
3	Remove the clamps fixing electric box cover, to remove the cover.	 
4	Remove every wiring terminals, and remove the screws fixing electric box cover, to remove the electric box cover sub-assy.	
7.Remove evaporator sub-assy		
1	Remove the screws fixing connection pipe clamp, to remove the connection pipe clamp.	 

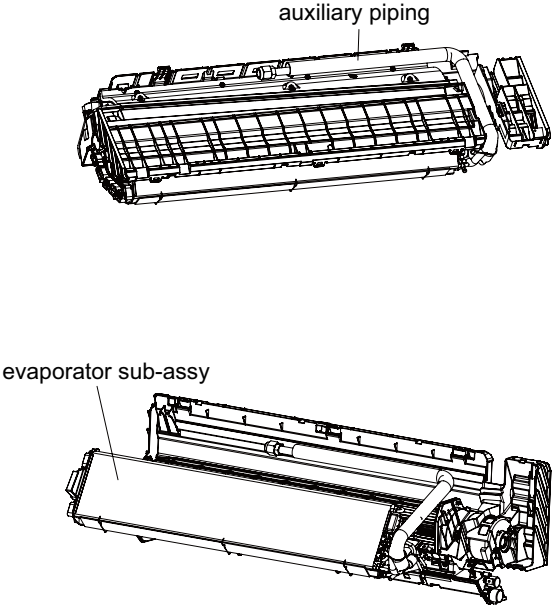
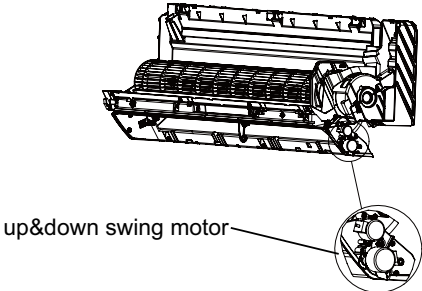
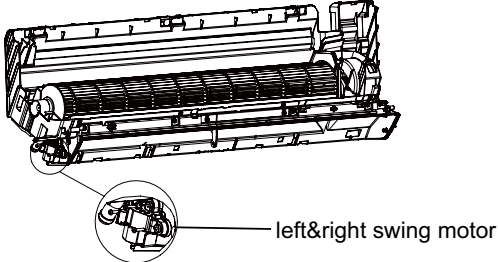
Steps	Procedure	
2	<p>Remove the screws fixing evaporator sub-assy, slightly regulate the tube, to remove the evaporator sub-assy.</p>	 <p>The diagram consists of two parts. The upper part shows a perspective view of a long, cylindrical component with a grid-like structure, labeled 'auxiliary piping'. The lower part shows a similar component with a flat, rectangular section attached to its side, labeled 'evaporator sub-assy'.</p>
8.Remove cross fan blade and motor		
1	<p>Remove the screws fixing up&down swing motor, to remove the motor.</p>	 <p>The diagram shows a perspective view of a motor assembly with a cylindrical fan blade. Below it is a circular inset showing a close-up of the motor's mounting mechanism, labeled 'up&down swing motor'.</p>
2	<p>Remove the screws fixing left&right swing motor, to remove the motor.</p>	 <p>The diagram shows a perspective view of a motor assembly with a cylindrical fan blade. Below it is a circular inset showing a close-up of the motor's mounting mechanism, labeled 'left&right swing motor'.</p>

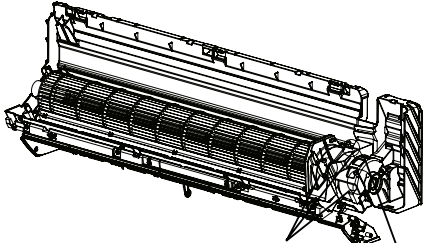
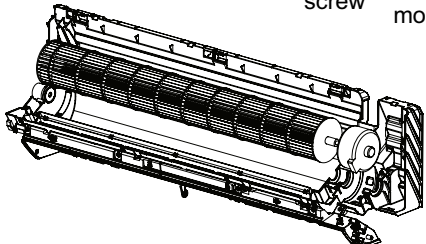
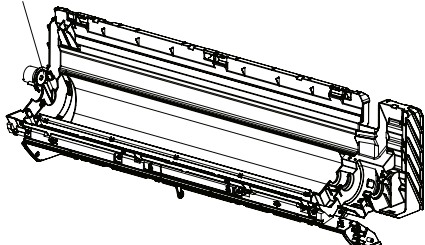
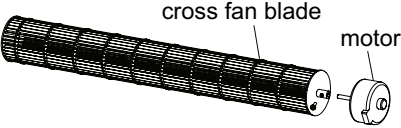
Steps	Procedure	
3	Remove the screws fixing motor clamp, to remove the motor clamp.	 <p>screw motor clamp</p>
4	Remove the cross fan blade and motor.	
5	Remove the shafting bearing cushion rubber base	<p>bearing cushion rubber base</p> 
6	Remove the screws fixing cross fan blade and motor, and then remove the motor.	<p>cross fan blade motor</p> 

Appendix:

Appendix 1: Reference Sheet of Celsius and Fahrenheit

Conversion formula for Fahrenheit degree and Celsius degree: $T_f = T_c \times 1.8 + 32$

Set temperature

Fahrenheit display temperature (°F)	Fahrenheit (°F)	Celsius (°C)	Fahrenheit display temperature (°F)	Fahrenheit (°F)	Celsius (°C)	Fahrenheit display temperature (°F)	Fahrenheit (°F)	Celsius (°C)
61	60.8	16	69/70	69.8	21	78/79	78.8	26
62/63	62.6	17	71/72	71.6	22	80/81	80.6	27
64/65	64.4	18	73/74	73.4	23	82/83	82.4	28
66/67	66.2	19	723/326	75.2	24	84/85	84.2	29
68	68	20	77	77	25	86	86	30

Ambient temperature

Fahrenheit display temperature (°F)	Fahrenheit (°F)	Celsius (°C)	Fahrenheit display temperature (°F)	Fahrenheit (°F)	Celsius (°C)	Fahrenheit display temperature (°F)	Fahrenheit (°F)	Celsius (°C)
343/643	32	0	55/56	55.4	13	79/80	78.8	26
34/35	33.8	1	57/58	57.2	14	81	80.6	27
36	35.6	2	59/60	59	15	82/83	82.4	28
37/38	37.4	3	61/62	60.8	16	84/85	84.2	29
39/40	39.2	4	63	62.6	17	86/87	86	30
41/42	41	5	64/65	64.4	18	88/89	87.8	31
43/44	42.8	6	66/67	66.2	19	90	89.6	32
45	44.6	7	68/69	68	20	97/642	91.4	33
46/47	46.4	8	70/71	69.8	21	93/94	93.2	34
48/49	48.2	9	72	71.6	22	99/166	95	35
50/51	50	10	73/74	73.4	23	97/98	96.8	36
513/323	51.8	11	723/326	75.2	24	99	98.6	37
54	53.6	12	77/78	77	25			

Appendix 2: Configuration of Connection Pipe

- Standard length of connection pipe
 - 16ft, 24ft, 26ft.
- Min. length of connection pipe is 10ft.
- Max. length of connection pipe and max. high difference. (See the specification)
- The additional refrigerant oil and refrigerant charging required after prolonging connection pipe
 - After the length of connection pipe is prolonged for 33 ft. over at the basis of standard length, you should add .17 oz. of refrigerant oil for each additional 16.4 ft. of connection pipe.
 - The calculation method of additional refrigerant charging amount (on the basis of liquid pipe):
 - Basing on the length of standard pipe, add refrigerant according to the requirement as shown in the table. The additional refrigerant charging amount per meter is different according to the diameter of liquid pipe. See the following sheet.
 - Additional refrigerant charging amount = prolonged length of liquid pipe X additional refrigerant charging amount per foot.

Additional refrigerant charging amount for R22, R407C, R410A and R134a			
Diameter of connection pipe		Outdoor unit throttle	
Liquid pipe(inch)	Gas pipe(inch)	N/A	Cooling and heating (oz./ft.)
Φ1/4	Φ3/8 or Φ1/2	N/A	0.2
Φ1/4 or Φ3/8	Φ5/8 or Φ3/4	N/A	0.2
Φ1/2	Φ3/4 or Φ7/8	N/A	1.3
Φ5/8	Φ1 or Φ1 1/4	N/A	1.3
Φ3/4	/	N/A	2.7
Φ7/8	/	N/A	3.8

Appendix 3: Pipe Expanding Method

⚠ Note:

Improper pipe flaring is the main cause of refrigerant leakage. Please flare the pipe according to the following steps:

A: Cut the pipe

- Confirm the pipe length according to the distance between indoor unit and outdoor unit.
- Cut the required pipe with pipe cutter.

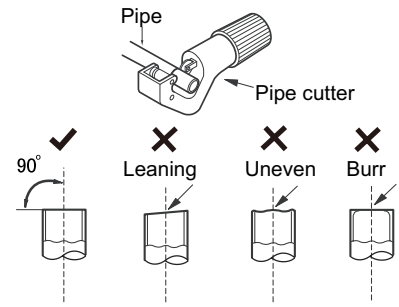

B: Remove the burrs

- Remove the burrs with shaper and prevent the burrs from getting into the pipe.

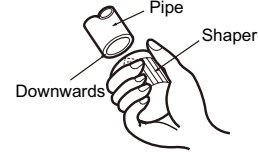

C: Put on suitable insulating pipe

D: Put on the flare nut

- Remove the flare nut on the indoor connection pipe and outdoor valve; install the flare nut on the pipe.

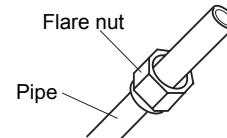

E: Flare the port

- Flare the port with expander.

⚠ Note:

- "A" is different according to the diameter, please refer to the sheet below:

Outer diameter(inch)	A(inch)	
	Max	Min
Φ1/4	43/649	1/36
Φ3/8	1/16	1/51
Φ1/2	1/14	1/51
Φ5/8	5/53	2/23

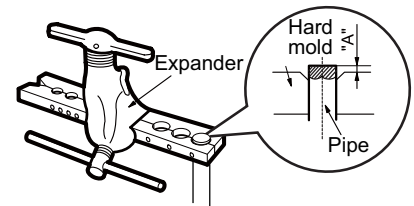

F: Inspection

- Check the quality of flare. If there is any blemish, flare the port again according to the steps above.

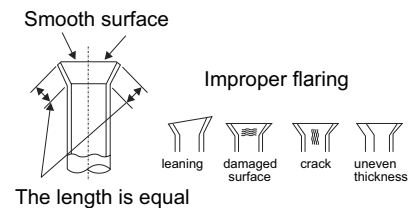

Appendix 4: List of Resistance for Temperature Sensor

Resistance Table of Ambient Temperature Sensor for Indoor and Outdoor Units(15K)

Temp.(°F)	Resistance(kΩ)	Temp.(°F)	Resistance(kΩ)	Temp.(°F)	Resistance(kΩ)	Temp.(°F)	Resistance(kΩ)
-2.2	138.1	68	18.75	138.2	3.848	208.4	1.071
-0.4	128.6	69.8	17.93	140	3.711	210.2	1.039
1.4	121.6	71.6	17.14	141.8	3.579	212	1.009
3.2	115	73.4	16.39	143.6	3.454	213.8	0.98
5	108.7	75.2	15.68	145.4	3.333	215.6	0.952
6.8	102.9	77	15	147.2	3.217	217.4	0.925
8.6	97.4	78.8	14.36	149	3.105	219.2	0.898
10.4	92.22	80.6	13.74	150.8	2.998	221	0.873
12.2	87.35	82.4	13.16	152.6	2.896	222.8	0.848
14	82.75	84.2	12.6	154.4	2.797	224.6	0.825
15.8	78.43	86	12.07	156.2	2.702	226.4	0.802
17.6	74.35	87.8	11.57	158	2.611	228.2	0.779
19.4	70.5	89.6	11.09	159.8	2.523	230	0.758
21.2	66.88	91.4	10.63	161.6	2.439	231.8	0.737
23	63.46	93.2	10.2	163.4	2.358	233.6	0.717
24.8	60.23	95	9.779	165.2	2.28	235.4	0.697
26.6	57.18	96.8	9.382	167	2.206	237.2	0.678
28.4	54.31	98.6	9.003	168.8	2.133	239	0.66
30.2	51.59	100.4	8.642	170.6	2.064	240.8	0.642
32	49.02	102.2	8.297	172.4	1.997	242.6	0.625
33.8	46.6	104	7.967	174.2	1.933	244.4	0.608
35.6	44.31	105.8	7.653	176	1.871	246.2	0.592
37.4	42.14	107.6	7.352	177.8	1.811	248	0.577
39.2	40.09	109.4	7.065	179.6	1.754	249.8	0.561
41	38.15	111.2	6.791	181.4	1.699	251.6	0.547
42.8	36.32	113	6.529	183.2	1.645	253.4	0.532
44.6	34.58	114.8	6.278	185	1.594	255.2	0.519
46.4	32.94	116.6	6.038	186.8	1.544	257	0.505
48.2	31.38	118.4	5.809	188.6	1.497	258.8	0.492
50	29.9	120.2	5.589	190.4	1.451	260.6	0.48
51.8	28.51	122	5.379	192.2	1.408	262.4	0.467
53.6	27.18	123.8	5.197	194	1.363	264.2	0.456
55.4	25.92	125.6	4.986	195.8	1.322	266	0.444
57.2	24.73	127.4	4.802	197.6	1.282	267.8	0.433
59	23.6	129.2	4.625	199.4	1.244	269.6	0.422
60.8	22.53	131	4.456	201.2	1.207	271.4	0.412
62.6	21.51	132.8	4.294	203	1.171	273.2	0.401
64.4	20.54	134.6	4.139	204.8	1.136	275	0.391
66.2	19.63	136.4	3.99	206.6	1.103	276.8	0.382

Resistance Table of Ambient Temperature Sensor for Indoor and Outdoor Units(20K)

Temp.(°F)	Resistance(kΩ)	Temp.(°F)	Resistance(kΩ)	Temp.(°F)	Resistance(kΩ)	Temp.(°F)	Resistance(kΩ)
-2.2	181.4	68	25.01	138.2	5.13	208.4	1.427
-0.4	171.4	69.8	23.9	140	4.948	210.2	1.386
1.4	162.1	71.6	22.85	141.8	4.773	212	1.346
3.2	153.3	73.4	21.85	143.6	4.605	213.8	1.307
5	145	75.2	20.9	145.4	4.443	215.6	1.269
6.8	137.2	77	20	147.2	4.289	217.4	1.233
8.6	129.9	78.8	19.14	149	4.14	219.2	1.198
10.4	123	80.6	18.13	150.8	3.998	221	1.164
12.2	116.5	82.4	17.55	152.6	3.861	222.8	1.131
14	110.3	84.2	16.8	154.4	3.729	224.6	1.099
15.8	104.6	86	16.1	156.2	3.603	226.4	1.069
17.6	99.13	87.8	15.43	158	3.481	228.2	1.039
19.4	94	89.6	14.79	159.8	3.364	230	1.01
21.2	89.17	91.4	14.18	161.6	3.252	231.8	0.983
23	84.61	93.2	13.59	163.4	3.144	233.6	0.956
24.8	80.31	95	13.04	165.2	3.04	235.4	0.93
26.6	76.24	96.8	12.51	167	2.94	237.2	0.904
28.4	72.41	98.6	12	168.8	2.844	239	0.88
30.2	68.79	100.4	11.52	170.6	2.752	240.8	0.856
32	65.37	102.2	11.06	172.4	2.663	242.6	0.833
33.8	62.13	104	10.62	174.2	2.577	244.4	0.811
35.6	59.08	105.8	10.2	176	2.495	246.2	0.77
37.4	56.19	107.6	9.803	177.8	2.415	248	0.769
39.2	53.46	109.4	9.42	179.6	2.339	249.8	0.746
41	50.87	111.2	9.054	181.4	2.265	251.6	0.729
42.8	48.42	113	8.705	183.2	2.194	253.4	0.71
44.6	46.11	114.8	8.37	185	2.125	255.2	0.692
46.4	43.92	116.6	8.051	186.8	2.059	257	0.674
48.2	41.84	118.4	7.745	188.6	1.996	258.8	0.658
50	39.87	120.2	7.453	190.4	1.934	260.6	0.64
51.8	38.01	122	7.173	192.2	1.875	262.4	0.623
53.6	36.24	123.8	6.905	194	1.818	264.2	0.607
55.4	34.57	125.6	6.648	195.8	1.736	266	0.592
57.2	32.98	127.4	6.403	197.6	1.71	267.8	0.577
59	31.47	129.2	6.167	199.4	1.658	269.6	0.563
60.8	30.04	131	5.942	201.2	1.609	271.4	0.549
62.6	28.68	132.8	5.726	203	1.561	273.2	0.535
64.4	27.39	134.6	5.519	204.8	1.515	275	0.521
66.2	26.17	136.4	5.32	206.6	1.47	276.8	0.509

Resistance Table of Ambient Temperature Sensor for Indoor and Outdoor Units(50K)

Temp.(°F)	Resistance(kΩ)	Temp.(°F)	Resistance(kΩ)	Temp.(°F)	Resistance(kΩ)	Temp.(°F)	Resistance(kΩ)
-20.2	853.5	50	98	120.2	18.34	190.4	4.754
-18.4	799.8	51.8	93.42	122	17.65	192.2	4.609
-16.6	750	53.6	89.07	123.8	16.99	194	4.469
-14.8	703.8	55.4	84.95	125.6	16.36	195.8	4.334
-13	660.8	57.2	81.05	127.4	15.75	197.6	4.204
-11.2	620.8	59	77.35	129.2	15.17	199.4	4.079
-9.4	580.6	60.8	73.83	131	14.62	201.2	3.958
-7.6	548.9	62.6	70.5	132.8	14.09	203	3.841
-5.8	516.6	64.4	67.34	134.6	13.58	204.8	3.728
-4	486.5	66.2	64.33	136.4	13.09	206.6	3.619
-2.2	458.3	68	61.48	138.2	12.62	208.4	3.514
-0.4	432	69.8	58.77	140	12.17	210.2	3.413
1.4	407.4	71.6	56.19	141.8	11.74	212	3.315
3.2	384.5	73.4	53.74	143.6	11.32	213.8	3.22
5	362.9	75.2	51.41	145.4	10.93	215.6	3.129
6.8	342.8	77	49.19	147.2	10.54	217.4	3.04
8.6	323.9	78.8	47.08	149	10.18	219.2	2.955
10.4	306.2	80.6	45.07	150.8	9.827	221	2.872
12.2	289.6	82.4	43.16	152.6	9.489	222.8	2.792
14	274	84.2	41.34	154.4	9.165	224.6	2.715
15.8	259.3	86	39.61	156.2	8.854	226.4	2.64
17.6	245.6	87.8	37.96	158	8.555	228.2	2.568
19.4	232.6	89.6	36.38	159.8	8.268	230	2.498
21.2	220.5	91.4	34.88	161.6	7.991	231.8	2.431
23	209	93.2	33.45	163.4	7.726	233.6	2.365
24.8	198.3	95	32.09	165.2	7.47	235.4	2.302
26.6	199.1	96.8	30.79	167	7.224	237.2	2.241
28.4	178.5	98.6	29.54	168.8	6.998	239	2.182
30.2	169.5	100.4	28.36	170.6	6.761	240.8	2.124
32	161	102.2	27.23	172.4	6.542	242.6	2.069
33.8	153	104	26.15	174.2	6.331	244.4	2.015
35.6	145.4	105.8	25.11	176	6.129	246.2	1.963
37.4	138.3	107.6	24.13	177.8	5.933	248	1.912
39.2	131.5	109.4	23.19	179.6	5.746	249.8	1.863
41	125.1	111.2	22.29	181.4	5.565	251.6	1.816
42.8	119.1	113	21.43	183.2	5.39	253.4	1.77
44.6	113.4	114.8	20.6	185	5.222	255.2	1.725
46.4	108	116.6	19.81	186.8	5.06	257	1.682
48.2	102.8	118.4	19.06	188.6	4.904	258.8	1.64



LIMITED EXPRESS WARRANTY

Congratulations on purchasing your new HVAC equipment. It's been designed for long life and reliable service, and is backed by one of the strongest warranties in the industry. Your unit automatically qualifies for the warranty coverage listed below, providing you keep your proof of purchase (receipt) for the equipment and meet the warranty conditions.

LIMITED FIVE (5) YEAR EXPRESS WARRANTY

Heat Controller warrants all parts of the VFH Series Ductless Mini-Split to be free from defects in workmanship and materials for normal use and maintenance for five (5) years from the date of purchase by the original consumer for the original installation. This Express Limited Warranty applies only when the Ductless Mini-Split is installed as a complete matched system: outdoor unit and indoor unit, and only when the system is installed per Heat Controller installation instructions and in accordance with all local, state and national codes for normal use.

LIMITED 6th to 7th YEAR EXPRESS WARRANTY

The compressor only is warranted to be free from defects in workmanship and materials for normal use and maintenance for two (2) additional years, for a total of seven (7) years from the date of purchase by the original consumer for the original installation. This Express Limited Warranty applies only when the Ductless Mini-Split is installed as a complete matched system: outdoor unit and indoor unit, and only when the system is installed per Heat Controller installation instructions and in accordance with all local, state and national codes for normal use.

EXCEPTIONS

The Limited Express Warranty does not cover normal maintenance—Heat Controller recommends that regular inspection/maintenance be performed at least once a season and proof of maintenance be kept. Additionally, labor charges, transportation charges for replacement parts, replacement of refrigerant or filters, any other service calls/repairs are not covered by this Limited Warranty. It also does not cover any portion or component of the system that is not supplied by Heat Controller, regardless of the cause of failure of such portion or component.

CONDITIONS FOR WARRANTY COVERAGE

- Unit must be operated according to Heat Controller operating instructions included with the unit and cannot have been subjected to accident, alteration, improper repair, neglect or misuse, or an act of God (such as a flood)
- Installation was done by a trained, licensed or otherwise qualified HVAC dealer/contractor
- Performance cannot be impaired by use of any product not authorized by Heat Controller, or by any adjustments or adaptations to components
- Serial numbers and/or rating plate have not been altered or removed
- Damage has not been a result of inadequate wiring or voltage conditions, use during brown-out conditions, or circuit interruptions
- Air flow around any section of the unit has not been restricted
- Unit remains in the original installation
- Unit was not purchased over the internet

Please visit www.heatcontroller.com to register your new product



DURATION OF WARRANTY & REGISTRATION

The warranty begins on the date of purchase by the original consumer. The consumer must retain a receipted bill of sale as proof of warranty period. Without this proof, the express warranty begins on the date of shipment from the factory.

REMEDY PROVIDED BY THE LIMITED EXPRESS WARRANTY

The sole remedy under the Limited Warranty is replacement of the defective part. If replacement parts are required within the period of this warranty, Heat Controller replacement parts shall be used; any warranty on the replacement part(s) shall not affect the applicable original unit warranty. Ready access to the unit for service is the owner's responsibility. Labor to diagnose and replace the defective part is not covered by this Limited Express Warranty. If for any reason the replacement part/product is no longer available during the warranty period, Heat Controller shall have the right to allow a credit in the amount of the current suggested retail price of the part/product instead of providing repair or replacement.

LIMITATION OF LIABILITY

1. There are no other express or implied warranties. Heat Controller makes no warranty of merchantability. We do not warrant that the unit is suitable for any particular purpose or can be used in buildings or rooms of any particular size or condition except as specifically provided in this document. There are no other warranties, express or implied, which extend beyond the description in this document.
2. All warranties implied by law are limited in duration to the seven-year term of the parts warranty. Your exclusive remedy is limited to the replacement of defective parts. **We will not be liable for any consequential or incidental damages caused by any defect in this unit.**
3. This warranty gives you specific legal rights and you may also have other rights which vary from state to state. Some states do not allow limitation on how long an implied warranty lasts or do not allow the exclusion or limitation of incidental or consequential damages, so the above limitations or exclusions may not apply to you.
4. No warranties are made for units sold outside the continental United States and Canada. Your distributor or final seller may provide a warranty on units sold outside these areas.
5. Heat Controller will not be liable for damages if our performance regarding warranty resolution is delayed by events beyond our control including accident, alteration, abuse, war, government restrictions, strikes, fire, flood, or other acts of God.

HOW TO OBTAIN WARRANTY SERVICE OR PARTS

If you have a warranty claim, notify your installer promptly. If the installer does not remedy your claim, write to Heat Controller, 1900 Wellworth Ave., Jackson MI 49203. Enclose a report of inspection by your installer or service person. Include model number, serial number, and date of purchase.

Owner responsibilities are set forth in the instruction manual—read it carefully.

KEEP THIS INFORMATION AS A RECORD OF YOUR PURCHASE

Outdoor Unit: Model No. _____ Serial No. _____

Indoor Unit 1: Model No. _____ Serial No. _____

Indoor Unit 2: Model No. _____ Serial No. _____

Indoor Unit 3: Model No. _____ Serial No. _____

Indoor Unit 4: Model No. _____ Serial No. _____

Indoor Unit 5: Model No. _____ Serial No. _____

Date of Purchase _____

THIS PAGE IS INTENTIONALLY LEFT BLANK

THIS PAGE IS INTENTIONALLY LEFT BLANK

Due to ongoing product improvements, specifications and dimensions are subject to change and correction without notice or incurring obligations. Determining the application and suitability for use of any product is the responsibility of the installer. Additionally, the installer is responsible for verifying dimensional data on the actual product prior to beginning any installation preparations.

Incentive and rebate programs have precise requirements as to product performance and certification. All products meet applicable regulations in effect on date of manufacture; however, certifications are not necessarily granted for the life of a product. Therefore, it is the responsibility of the applicant to determine whether a specific model qualifies for these incentive/rebate programs.

Comfort-Aire® **Century**®